

Profile milling

Inserts

Face milling cutters

Square shoulder cutters

Slot cutters

Porcupine cutters

Specific applications and Sets

Profile milling

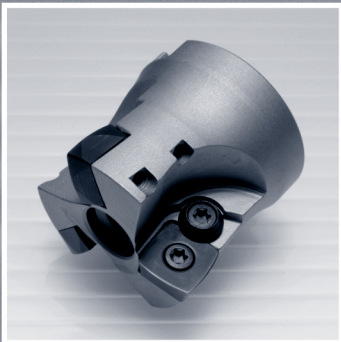

Profile milling

Technical information	G.02
Applications	G.03
Roughing ball nose	G.04
Finishing ball nose	G.08
Toroidal cutters	G.14
High feed	G.18
Round inserts	G.24
Aluminium die cutting	G.30

Inserts

Face milling cutters

Square shoulder cutters

Slot cutters

Porcupine cutters

Specific applications and Sets

Profile milling

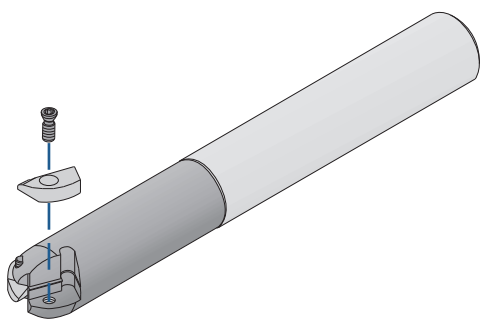

Screw clamping

Since the advent of the Torx screw it has been possible to hold with complete safety positive inserts with center hole. Our range covers all the screw clamping permutations.

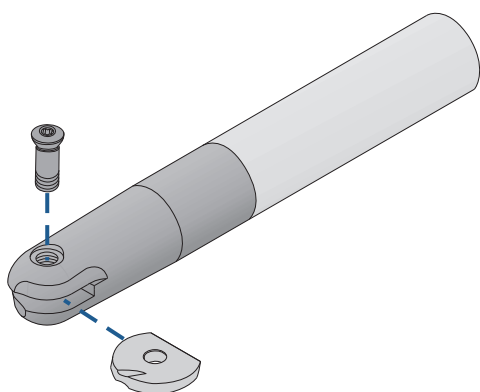

Center screw clamping

Grinded high accuracy center screws ensures that the insert is firmly fixed. This clamping system is only used for finishing applications.

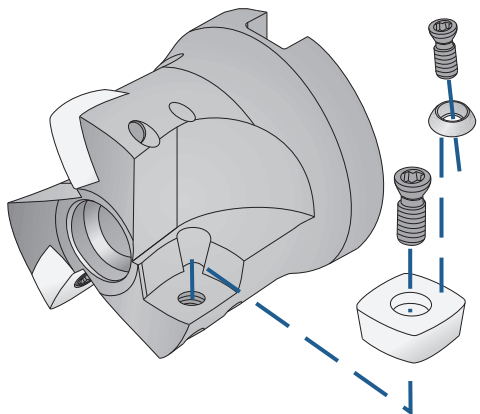

Double clamping

Heavy duty work require good fixation, for this purpose we have as designed our double clamping system, one of the safest available.

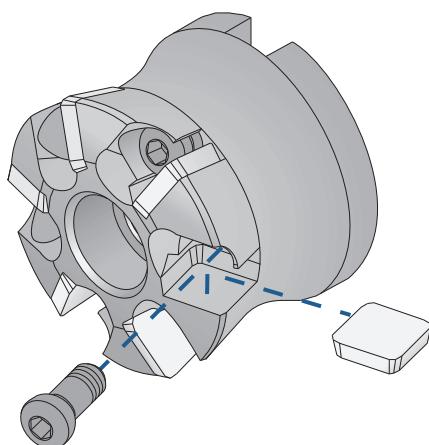

Wedge screw

This easy and clean clamping system has been designed for the high feed cutters with flat inserts. The wedge screw clamping system offers good chip evacuation and easy use.

Roughing ball nose

3540.0¹
Roughing (Cylindric)



Page G.04 IN.. 25
IN.. 32

3540.3⁴
Roughing (Morse)



IN.. 32
... IN.. 50
Page G.05

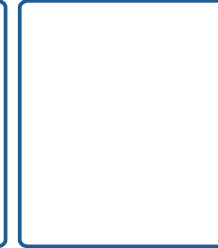
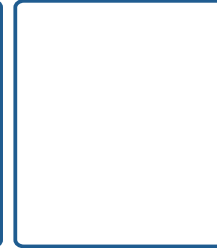
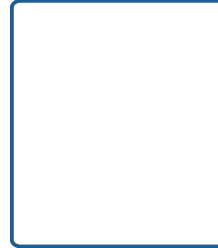

Finishing ball nose

85_0
Copy applications (Finishing) Cylindric



HPR 10
... HPR 32
Page G.08

85_3
Copy applications (Finishing) Morse



HPR 20
... HPR 32
Page G.09

85_06
Copy applications (Finishing) Modular



HPR 10
... HPR 25
Page G.10

88_0
Copy applications (Finishing) Cylindric



RPR 10
... RPR 32
Page G.11

88_3
Copy applications (Finishing) Morse



RPR 20
... RPR 32
Page G.12

88_06
Copy applications (Finishing) Modular



RPR 10
... RPR 25
Page G.13

Toroidal cutters

89_01
Back draft cutter Cylindric



MTK 12
MTK ...
MTK 25
Page G.14

89_06
Back draft cutter Modular



MTK 10
MTK ...
MTK 25
Page G.15

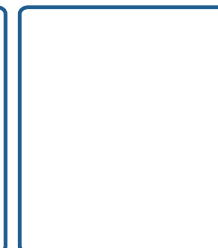
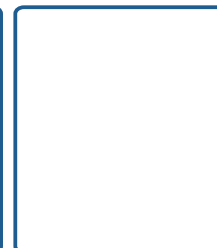
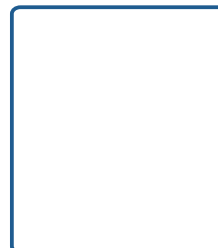

High feed

1635.00 High feed



Page G.18 XDKW 0904..

1645.90 High feed



Page G.19 XDKW 1205..

1440.90 High feed



Page G.20 SP.. 1203..

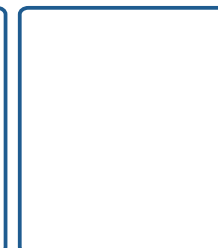
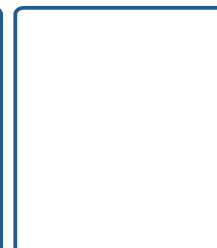
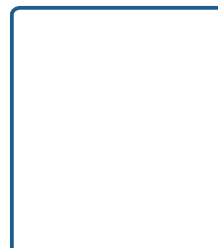

Round Inserts

55_5 Round milling



RDHW 0702..
RDHW 1604..
Page G.24

55_5.06 Round milling



RDHW 0702..
RDHW 1604..
Page G.25

55⁴5.90 Round milling



RD.. 12T3M0
RD.. 1604M0
Page G.26

5549.90 Round milling

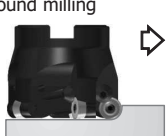

RPM.. 1204..
Page G.27

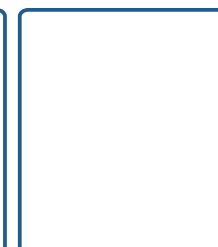

Aluminium die cutting

0344.06
General application



VC.. 1103..
VC.. 2205..
Page G.30

0344.90
General application



VC.. 2205..
Page G.31

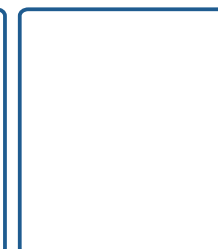

Inserts

Face milling cutters

Square shoulder cutters

Slot cutters

Porcupine cutters

Specific applications and Sets

Profile milling

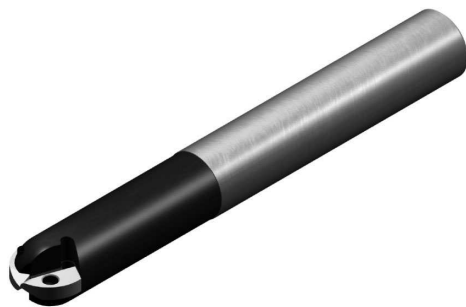

Characteristics:

Indexable ball nose roughing cutter equipped with positive insert that provides low cutting forces and reduced vibration. Its accurate pocket ensures that the insert is firmly fixed. The insert is fixed by Torx screw that allow a good chip evacuation and easy use. Milling cutter equipped with cylindric shank.

Applications:

Ball end mill roughing applications for tool and die. This indexable ball nose cutter works well on steels, hardened steels, stainless steels and casts.

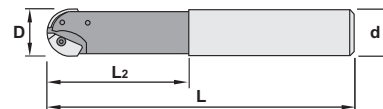
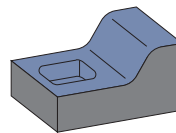
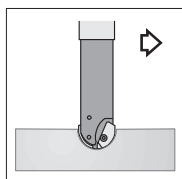

3540.01

Ref.			D	L	L2	d	Insert size	
3540.00.025	2	25	115	57	25	IN.. 25	0,400	
3540.00.032	2	32	115	57	32	IN.. 32	0,500	
3540.01.025	2	25	150	76	25	IN.. 25	0,650	
3540.01.032	2	32	150	76	32	IN.. 32	0,850	



Ref.			
3540.00.025	1235	5615	
3540.00.032	1550	5620	
3540.01.025	1235	5615	
3540.01.032	1550	5620	

		IN..	l	s	d	Positive ball nose insert.
Ref.	IN.. 25	-	4,5	12,5		
	IN.. 32	-	5,6	16,0		
For more information see page: A.13						
	INT	INW				

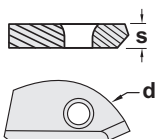



Characteristics:

Indexable ball nose roughing cutter equipped with positive insert that provides low cutting forces and reduced vibration. Its accurate pocket ensures that the insert is firmly fixed.

The insert is fixed by Torx screw that allow a good chip evacuation and easy use.

Milling cutter equipped with Morse shank.

Applications:

Ball end mill roughing applications for tool and die. This indexable ball nose cutter works well on steels, hardened steels, stainless steels and casts.

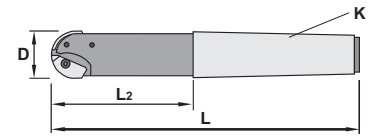
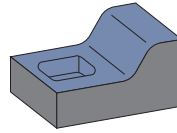
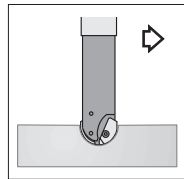

3540.345

Ref.		D	L	L2	K	Insert size	
3540.34.032	2	32	228	119	4	IN.. 32	1,150
3540.35.040	2	40	231	95	5	IN.. 40	2,120
3540.35.050	2	50	231	95	5	IN.. 50	2,850

Ref.		
3540.34.032	1550	5620
3540.35.040	1250	5620
3540.35.050	1890	5625

Ref.	IN..			Positive ball nose insert.
	l	s	d	
IN.. 32	-	5,6	16,0	For more information see page: A.13
IN.. 40	-	5,6	20,0	
IN.. 50	-	7,9	25,0	
	INT	INW		

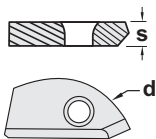

Recommended cutting conditions

Side Milling

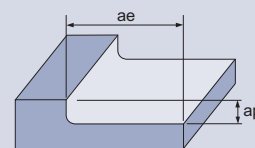

Material	m/min Actual Maximum Cutting Speed	mm/tooth Feed rate	Ø20		Ø25		Ø32		Ø40	
			min ⁻¹	mm/min	min ⁻¹	mm/min	min ⁻¹	mm/min	min ⁻¹	mm/min
Carbon Steels (200 HB)	150-250	0,15-0,6	3500	4200	2800	3360	2330	2800	1430	1720
		Vc=220m/min ap<=1,0mm ae=0,3D								
Alloy Steels (200-250 HB)	120-200	0,1-0,3	3500	650	2800	880	2330	720	1430	540
		Vc=220m/min ap=0,5mm ae=0,3D								
Alloy Steels (25-35 HRC)	60-120	0,15-0,6	3180	3820	2550	3060	2120	2550	1270	1530
		Vc=200m/min ap<=1,0mm ae=0,3D								
Alloy Steels (25-35 HRC)	60-120	0,08-0,3	3180	540	2550	660	2120	530	1270	410
		Vc=200m/min ap=0,5mm ae=0,3D								
Alloy Steels (25-35 HRC)	60-120	0,08-0,6	2070	2500	1660	2000	1380	1650	870	1050
		Vc=130m/min ap<=1,0mm ae=0,3D								
Alloy Steels Pre-Harden Steels (40-45 HRC)	50-100	0,05-0,3	2070	440	1660	540	1380	460	870	330
		Vc=130m/min ap=0,5mm ae=0,3D								
Cast Iron (150HB)	120-240	0,07-0,6	1110	1330	890	1070	740	900	560	670
		Vc=70m/min ap<=1,0mm ae=0,3D								
Cast Iron (150HB)	120-240	0,05-0,3	1110	150	890	200	740	200	560	100
		Vc=70m/min ap=0,5mm ae=0,3D								
Cast Iron (150HB)	120-240	0,15-1,2	3500	4200	2800	3360	2230	2800	1430	1720
		Vc=220m/min ap<=1,0mm ae=0,3D								
Cast Iron (150HB)	120-240	0,1-0,3	3500	650	2800	900	2230	900	1430	540
		Vc=220m/min ap=0,5mm ae=0,3D								

Note

- The cutting data in the table show conditions for VB30=0,3mm (flank wear 30min tool-life).
Overhang is the length below the chuck (l b)

- RPM for high-speed machines is calculated using the following formula: $Revolution\ Speed = \frac{500 \times Actual\ Maximum\ Cutting\ Speed}{\pi \times \sqrt{2} \times R \times ap \cdot ap^2}$

- Actual Maximum Cutting Speed:
ap=0,5mm and 1mm
Maximum Cutting Speed at boundary of contact part with work material under the above recommended cutting condition

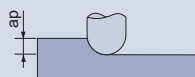

- Cutting conditions on high-speed machine tools are recommended for contouring path milling.

- 3-5° slant milling is recommended for pocketing using a 70% feed rate, please reduce slant angle below 3° for harder materials. Please use machine guards when cutting steel due to flying chips.

Deep Side Milling

Material	m/min Cutting Speed	mm/tooth Feed rate	Ø20		Ø25		Ø30		Ø40	
			min ⁻¹	mm/min	min ⁻¹	mm/min	min ⁻¹	mm/min	min ⁻¹	mm/min
Carbon Steels (200 HB)	120-200	0,08-0,2	2700	420	2160	530	1800	440	1110	420
			Vc=170m/min ap=1,2D ae=0,1D							
Alloy Steels (200-250 HB)	120-200	0,06-0,2	2550	320	2040	430	1700	350	1270	410
			Vc=160m/min ap=1,2D ae=0,1D							
Alloy Steels (25-35 HRC)	100-160	0,05-0,15	1750	220	1400	330	1170	270	790	300
			Vc=110m/min ap=1,2D ae=0,1D							
Hardened Steels Pre-Harden Steels (40-45 HRC)	60-120	0,04-0,13	960	70	760	100	640	100	480	90
			Vc=60m/min ap=1,2D ae=0,1D							
Cast Iron (150HB)	140-220	0,08-0,2	2700	420	2160	530	1800	440	1110	420
			Vc=170m/min ap=1,2D ae=0,1D							

Recommended cutting conditions

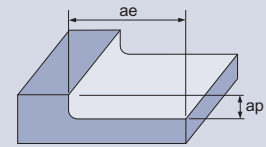

Slotting

Material	m/min Cutting Speed	mm/tooth Feed rate	Ø20		Ø25		Ø30		Ø40			
			min ⁻¹	mm/min	min ⁻¹	mm/min	min ⁻¹	mm/min	min ⁻¹	mm/min		
Carbon Steels (200 HB)	150-250	0,06-0,2	3500	440	2800	550	2330	720	1430	440		
			Vc=220m/min						Vc=180m/min			
			ap=0,3D									
Alloy Steels (200-250 HB)	150-230	0,05-0,2	3180	330	2550	450	2120	420	1270	340		
			Vc=200m/min						Vc=160m/min			
			ap=0,3D									
Alloy Steels (25-35 HRC)	100-160	0,03-0,15	2070	110	1660	210	1380	180	870	170		
			Vc=130m/min						Vc=110m/min			
			ap=0,3D									
Hardened Steels Pre-Harden Steels (40-45 HRC)	60-120	0,02-0,13	1100	50	890	80	740	80	560	100		
			Vc=70m/min									
			ap=0,3D									
Cast Iron (150HB)	140-240	0,06-0,2	3500	440	2800	660	2330	540	1430	540		
			Vc=220m/min						Vc=180m/min			
			ap=0,3D									

Note

- These conditions are for general guidance; in actual machining conditions adjust the parameters according to your actual machine and work-piece conditions.
- For long type please reduce speed and feed by 70%.
- In case of using Long Shank Type, no relation to diameters, basic conditions are:
 $n=700\text{min}^{-1}$
 $V_f=210\text{m/min}$
 $a_p=0,1D$
 $a_e=0,3D$

Inserts

Face milling cutters

Square shoulder cutters

Slot cutters

Porcupine cutters

Specific applications and Sets

Profile milling



Characteristics:

Indexable ball nose semi-finishing and finishing cutter equipped with positive insert that provides low cutting forces and reduced vibration. Its accurate pocket ensures that the insert is firmly fixed.

Milling cutter equipped with cylindric shank.

Applications:

Ball end mill for tool and die applications. This indexable ball nose cutter works well on steels, hardened steels, stainless steels and casts.

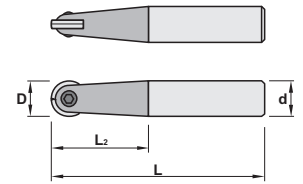
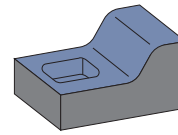
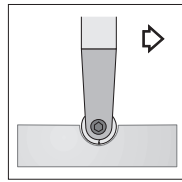

85_0

Ref.			D	L	L2	d	Insert size	
8530.00.010	2		10	105	35	12	HPR 10	0,100
8540.00.012	2		12	105	35	16	HPR 12	0,240
8550.00.016	2		16	105	45	20	HPR 16	0,260
8560.00.020	2		20	125	50	25	HPR 20	0,500
8580.00.025	2		25	125	55	32	HPR 25	0,750
8590.00.032	2		32	125	55	32	HPR 32	0,800
8530.01.010	2		10	150	50	12	HPR 10	0,200
8540.01.012	2		12	160	50	16	HPR 12	0,300
8550.01.016	2		16	180	70	20	HPR 16	0,400
8560.01.020	2		20	200	70	25	HPR 20	0,700
8580.01.025	2		25	220	100	32	HPR 25	1,250
8590.01.032	2		32	250	100	32	HPR 32	1,550

Ref.		
8530.00.010	1359	5615
8540.00.012	1509	5620
8550.00.016	1519	5620
8560.00.020	1529	5620
8580.00.025	1609	5530
8590.00.032	1809	5530
8530.01.010	1359	5615
8540.01.012	1509	5620
8550.01.016	1519	5620
8560.01.020	1529	5620
8580.01.025	1609	5530
8590.01.032	1809	5530

HPR		l	s	d	Positive 11° clearance - Round insert.
Ref.	HPR 10	-	2,40	10,00	
	HPR 12	-	2,50	12,00	
	HPR 16	-	3,00	16,00	
	HPR 20	-	3,00	20,00	
	HPR 25	-	4,00	25,00	
	HPR 32	-	5,00	32,00	

For more information see page: A.13



Characteristics:

Indexable ball nose semi-finishing and finishing cutter equipped with positive insert that provides low cutting forces and reduced vibration. Its accurate pocket ensures that the insert is firmly fixed.

Applications:

Ball end mill for tool and die applications. This indexable ball nose cutter works well on steels, hardened steels, stainless steels and casts.

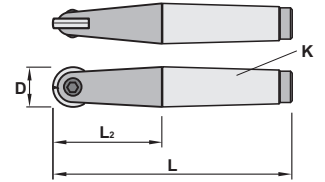
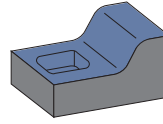
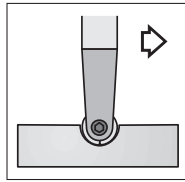

85_3

Ref.		D	L	K	L2	Insert size	
8560.30.020	2	20	190	3	115	HPR 20	0,670
8580.34.025	2	25	215	4	135	HPR 25	1,150
8590.34.032	2	32	268	4	160	HPR 32	1,550

Ref.		
8560.30.020	1529	5620
8580.34.025	1609	5530
8590.34.032	1809	5615

HPR		l	s	d	Positive 11° clearance - Round insert.
Ref.	HPR 20	-	3,00	20,00	
	HPR 25	-	4,00	25,00	
	HPR 32	-	5,00	32,00	

For more information see page: A.13

HPR					

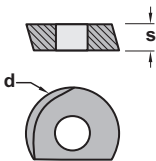

Inserts

Face milling cutters

Square shoulder cutters

Slot cutters

Porcupine cutters

Specific applications and Sets

Profile milling



Shanks page: K.45 - K.46

Characteristics:

Indexable ball nose semi-finishing and finishing cutter equipped with positive insert that provides low cutting forces and reduced vibration. Its accurate pocket ensures that the insert is firmly fixed. Milling cutter equipped with modular shank.

Applications:

Ball end mill for tool and die applications. This indexable ball nose cutter works well on steels, hardened steels, stainless steels and casts.

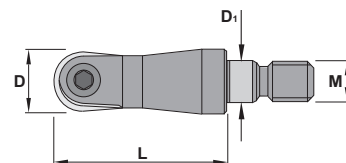
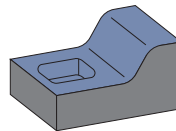
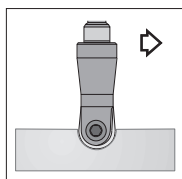

85_06			D	L	M	D1	Insert size	
Ref.	8530.06.010	2	10	23	M6	6,5	HPR 10	0,016
	8540.06.012	2	12	23	M6	6,5	HPR 12	0,030
	8550.06.016	2	16	30	M8	8,5	HPR 16	0,050
	8560.06.020	2	20	35	M10	10,5	HPR 20	0,095
	8580.06.025	2	25	40	M12	12,5	HPR 25	0,160

Ref.		
8530.06.010	1359	5515
8540.06.012	1509	5520
8550.06.016	1519	5520
8560.06.020	1529	5520
8580.06.025	1609	5530

HPR		l	s	d	Positive 11° clearance - Round insert.
Ref.	HPR 10	-	2,40	10,00	
	HPR 12	-	2,50	12,00	
	HPR 16	-	3,00	16,00	
	HPR 20	-	3,00	20,00	
	HPR 25	-	4,00	25,00	

For more information see page: A.13

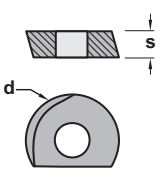



Characteristics:

Indexable ball nose mirror finishing cutter equipped with positive insert that provides low cutting forces and reduced vibration. Its accurate pocket ensures that the insert is firmly fixed.

Milling cutter equipped with cylindric shank.

Applications:

Ball end mill for tool and die applications. This indexable ball nose cutter works well on steels, hardened steels, stainless steels and casts.

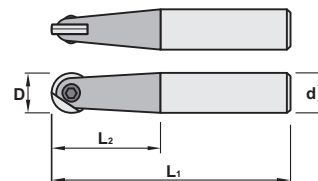
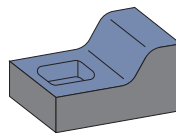
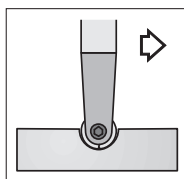

88_0

Ref.		D	L1	d	L2	Insert size	
8830.00.010	2	10	105	10	50	RPR 10	0,100
8840.00.012	2	12	105	12	50	RPR 12	0,240
8850.00.016	2	16	105	16	50	RPR 16	0,260
8860.00.020	2	20	125	20	70	RPR 20	0,500
8880.00.025	2	25	125	25	70	RPR 25	0,750
8890.00.032	2	32	125	32	70	RPR 32	0,800
8830.01.010	2	10	150	10	80	RPR 10	0,200
8840.01.012	2	12	160	12	90	RPR 12	0,300
8850.01.016	2	16	180	16	100	RPR 16	0,400
8860.01.020	2	20	200	20	120	RPR 20	0,700
8880.01.025	2	25	220	25	140	RPR 25	1,250
8890.01.032	2	32	250	32	160	RPR 32	1,550

Ref.		
8830.00.010	1353	5608
8840.00.012	1354	5610
8850.00.016	1619	5615
8860.00.020	1529	5620
8880.00.025	1609	5530
8890.00.032	1809	5530
8830.01.010	1353	5608
8840.01.012	1354	5610
8850.01.016	1619	5615
8860.01.020	1529	5620
8880.01.025	1609	5530
8890.01.032	1809	5530

RPR		l	s	d	Positive 11° clearance - Round insert.
Ref.	RPR 10	-	2,60	10,00	
	RPR 12	-	3,00	12,00	
	RPR 16	-	4,00	16,00	
	RPR 20	-	5,00	20,00	
	RPR 25	-	6,00	25,00	
	RPR 32	-	7,00	32,00	

For more information see page: A.16

Inserts

Face milling cutters

Square shoulder cutters

Slot cutters

Porcupine cutters

Specific applications and Sets

Profile milling



Characteristics:

Indexable ball nose mirror finishing cutter equipped with positive insert that provides low cutting forces and reduced vibration. Its accurate pocket ensures that the insert is firmly fixed.

Milling cutter equipped with Morse shank.

Applications:

Ball end mill for tool and die applications. This indexable ball nose cutter works well on steels, hardened steels, stainless steels and casts.

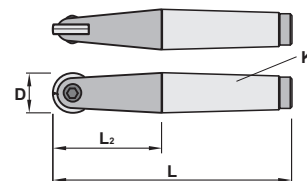
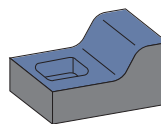
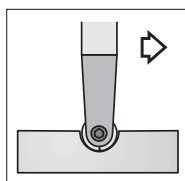

88_3			D	L	K	L2	Insert size	
Ref.	8860.30.020	2	20	190	3	115	RPR 20	0,670
	8880.34.025	2	25	215	4	135	RPR 25	1,200
	8890.34.032	2	32	268	4	160	RPR 32	1,650

Ref.		
8860.30.020	1529	5620
8880.34.025	1609	5530
8890.34.032	1809	5530

RPR		l	s	d	Positive 11° clearance - Round insert.
Ref.	RPR 20	-	5,00	20,00	For more information see page: A.19
	RPR 25	-	6,00	25,00	
	RPR 32	-	7,00	32,00	



Shanks page: K.45 - K.48

Characteristics:

Indexable ball nose mirror finishing cutter equipped with positive insert that provides low cutting forces and reduced vibration. Its accurate pocket ensures that the insert is firmly fixed.

Milling cutter equipped with modular shank.

Applications:

Ball end mill for tool and die applications. This indexable ball nose cutter works well on steels, hardened steels, stainless steels and casts.

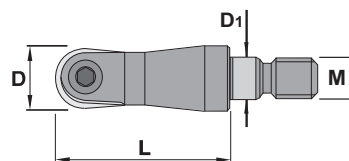
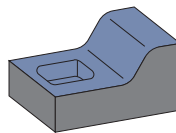
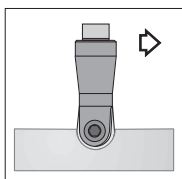

88_06

Ref.		D	L	M	D1	Insert size	
8830.06.010	2	10	23	M6	6,5	RPR 10	0,016
8840.06.012	2	12	23	M6	6,5	RPR 12	0,030
8850.06.016	2	16	30	M8	8,5	RPR 16	0,050
8860.06.020	2	20	30	M10	10,5	RPR 20	0,095
8880.06.025	2	25	35	M12	12,5	RPR 25	0,160

Ref.		
8830.06.010	1353	5508
8840.06.012	1354	5510
8850.06.016	1619	5515
8860.06.020	1529	5520
8880.06.025	1609	5530

RPR		l	s	d	Positive 11° clearance - Round insert.
Ref.	RPR 10	-	2,60	10,00	
	RPR 12	-	3,00	12,00	
	RPR 16	-	4,00	16,00	
	RPR 20	-	5,00	20,00	
	RPR 25	-	6,00	25,00	

For more information see page: A.19

Inserts

Face milling cutters

Square shoulder cutters

Slot cutters

Porcupine cutters

Specific applications and Sets

Profile milling



Characteristics:

Indexable back draft cutter equipped with positive insert that provides low cutting forces and reduced vibration. Its accurate pocket ensures that the insert is firmly fixed.

Milling cutter equipped with cylindric shank.

Applications:

Back draft cutter for tool and die applications. This indexable back draft cutter works well on steels, hardened steels, stainless steels and casts.

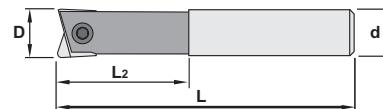
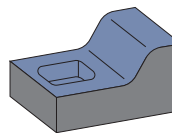
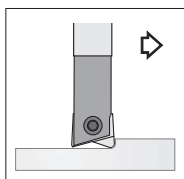

89_01

Ref.			D	L	d	L2	Insert size	
8940.01.012	2		12	110	12	53	MTK 12	0,090
8950.01.016	2		16	125	16	63	MTK 16	0,180
8960.01.020	2		20	140	20	75	MTK 20	0,290
8980.01.025	2		25	180	25	90	MTK 25	0,600

Ref.		
8940.01.012	1354	5608
8950.01.016	1619	5610
8960.01.020	1629	5615
8980.01.025	1609	5530

Ref.	MTK		Toroidal insert.
	l	r	
MTK 12	12,00	1,00	
MTK 16	16,00	1,30	
MTK 20	20,00	1,60	
MTK 25	25,00	2,00	
For more information see page: A.14			
	MTK		



Shanks page: K.45 - K.48

Characteristics:

Indexable back draft cutter equipped with positive insert that provides low cutting forces and reduced vibration. Its accurate pocket ensures that the insert is firmly fixed.

Applications:

Back draft cutter for tool and die applications. This indexable back draft cutter works well on steels, hardened steels, stainless steels and casts.

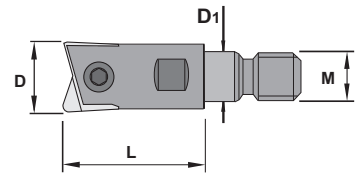
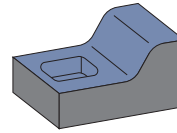
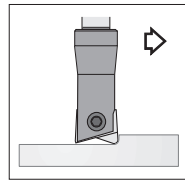

89_06

Ref.		D	L	M	D1	Insert size	
8930.06.010	2	10	23	M6	6,5	MTK 10	0,016
8940.06.012	2	12	23	M6	6,5	MTK 12	0,030
8950.06.016	2	16	30	M8	8,5	MTK 16	0,050
8960.06.020	2	20	30	M10	10,5	MTK 20	0,095
8980.06.025	2	25	35	M12	12,5	MTK 25	0,160

Ref.		
8930.06.010	1353	5508
8940.06.012	1354	5510
8950.06.016	1619	5515
8960.06.020	1629	5520
8980.06.025	1609	5530

Ref.	MTK		Toroidal insert.	
	l	r		
MTK 10	10,00	0,60		
MTK 12	12,00	1,00		
MTK 16	16,00	1,30		
MTK 20	20,00	1,60		
MTK 25	25,00	2,00		

For more information see page: A.14

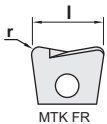

MTK



Inserts

Face milling cutters

Square shoulder cutters

Slot cutters

Porcupine cutters

Specific applications and Sets

Profile milling

Recommended cutting conditions

Material	m/min Cutting speed	mm/tooth Feed rate	Ø8		Ø10		Ø12			
			min ⁻¹	mm/min	min ⁻¹	mm/min	min ⁻¹	mm/min		
Carbon Steels Alloy Steels (30 HRC)	100-200	0,2-0,3	6370	2550	5090	2040	4240	1700		
			Vc=160m/min fz=0,2mm/tooth ap=0,025D ae=0,1D							
Carbon Steels Alloy Steels (30-40 HRC)	80-150	0,2-0,3	4770	1910	3820	1530	3180	1270		
			Vc=120m/min fz=0,2mm/tooth ap=0,025D ae=0,1D							
Die Tool Steels Pre-Harden Steels (30-40 HRC)	70-100	0,1-0,15	3180	640	2550	510	2120	420		
			Vc=80m/min fz=0,1mm/tooth ap=0,025D ae=0,1D							
Hardened Steels (55-65 HRC)	200-250	0,2-0,4	9150	3660	7320	2930	6100	2440		
			Vc=230m/min fz=0,2mm/tooth ap=0,01D ae=0,02D							
Cast Iron	100-200	0,3-0,4	6730	3820	5090	3050	4240	2550		
			Vc=160m/min fz=0,3mm/tooth ap=0,025D ae=0,1D							

Material	m/min Cutting speed	mm/tooth Feed rate	Ø16		Ø20		Ø25		Ø30(32)	
			min ⁻¹	mm/min	min ⁻¹	mm/min	min ⁻¹	mm/min	min ⁻¹	mm/min
Carbon Steels Alloy Steels (30 HRC)	100-200	0,2-0,3	2400	1600	2550	1300	2050	1030	1700	850
			Vc=160m/min fz=0,25mm/tooth ap=0,05D ae=0,1D							
Carbon Steels Alloy Steels (30-40 HRC)	80-150	0,2-0,3	1600	1200	1910	955	1530	765	1280	640
			Vc=120m/min fz=0,25mm/tooth ap=0,05D ae=0,1D							
Die Tool Steels Pre-Harden Steels (30-40 HRC)	70-100	0,1-0,15	3200	385	1280	310	1020	245	850	205
			Vc=80m/min fz=0,12mm/tooth ap=0,05D ae=0,1D							
Hardened Steels (55-65 HRC)	200-250	0,2-0,4	4575	2740	3660	2200	2930	1760	2440	1460
			Vc=230m/min fz=0,3mm/tooth ap=0,01D ae=0,02D							
Cast Iron	100-200	0,3-0,4	3200	2240	2550	1790	2050	1440	1700	1190
			Vc=160m/min fz=0,35mm/tooth ap=0,05D ae=0,1D							

Note

- According to the machining situation, refer to the table above to determine the cutting conditions.
 - Be sure to practice safety instructions and precautions such as wearing glasses and safety shoes, and placing safety covers when you use this tool. Because this tool can be broken during machining so failure to follow these instructions may cause personal injury.
 - Never attempt to modify the carbide shank holder. Use the value for the depth of cut (ap) when the carbide shank holder is used.
- Mill diameters D=8~12mm:ap<=0,2mm.
Mill diameters D=16~32mm:ap<=0,3mm.

$$n = \frac{Vc \cdot 1000}{\pi \cdot Def.} \text{ (Rev./min.)}$$

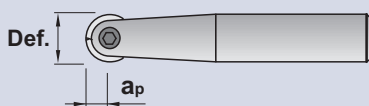

N = Spindle speed (Rev./min.)

Vc = Cutting speed

Def. = Effective cutting diameter

ap = Max. Depth of cut (mm)

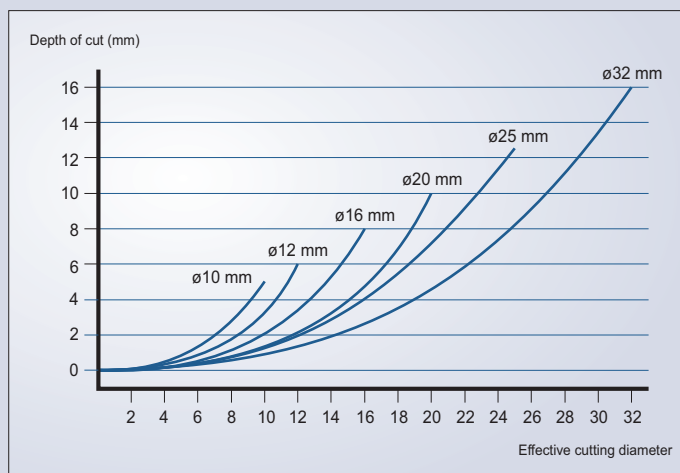

Recommended cutting conditions

Material	m/min Cutting speed	mm/tooth Feed rate	Ø10		Ø12	
			min ⁻¹	mm/min	min ⁻¹	mm/min
Carbon Steels Alloy Steels (30 HRC)	100-200	0,1-0,2	5090	2040	4240	1700
			Vc=160m/min fz=0,2mm/tooth ap=0,025D ae=0,1D			
Carbon Steels Alloy Steels (30-40 HRC)	80-150	0,1-0,2	3820	1530	3180	1270
			Vc=120m/min fz=0,2mm/tooth ap=0,025D ae=0,1D			
Die Tool Steels Pre-Harden Steels (30-40 HRC)	70-100	0,05-0,1	2550	510	2120	420
			Vc=80m/min fz=0,1mm/tooth ap=0,025D ae=0,1D			
Hardened Steels (55-65 HRC)	130-180	0,05-0,1	5090	1020	4240	850
			Vc=160m/min fz=0,1mm/tooth ap=0,01D ae=0,02D			
Cast Iron	100-200	0,2-0,3	5090	3050	4240	2550
			Vc=160m/min fz=0,3mm/tooth ap=0,025D ae=0,1D			

Material	m/min Cutting speed	mm/tooth Feed rate	Ø16		Ø20		Ø25		Ø30(32)	
			min ⁻¹	mm/min	min ⁻¹	mm/min	min ⁻¹	mm/min	min ⁻¹	mm/min
Carbon Steels Alloy Steels (30 HRC)	100-200	0,1-0,2	3200	1600	2550	1300	2050	1030	1700	850
			Vc=160m/min fz=0,25mm/tooth ap=0,05D ae=0,1D							
Carbon Steels Alloy Steels (30-40 HRC)	80-150	0,1-0,2	2400	1200	1910	955	1530	765	1280	640
			Vc=120m/min fz=0,25mm/tooth ap=0,05D ae=0,1D							
Die Tool Steels Pre-Harden Steels (30-40 HRC)	70-100	0,05-0,1	1600	385	1280	310	1020	245	850	205
			Vc=80m/min fz=0,12mm/tooth ap=0,05D ae=0,1D							
Hardened Steels (55-65 HRC)	130-180	0,05-0,1	3180	950	2550	760	2040	610	1700	510
			Vc=160m/min fz=0,15mm/tooth ap=0,01D ae=0,02D							
Cast Iron	100-200	0,2-0,3	3200	2240	2550	1790	2050	1440	1700	1190
			Vc=160m/min fz=0,35mm/tooth ap=0,05D ae=0,1D							

Note

- According to the machining situation, refer to the table above to determine the cutting conditions.
- Be sure to practice safety instructions and precautions such as wearing glasses and safety shoes, and placing safety covers when you use this tool.
- Because this tool can be broken during machining so failure to follow these instructions may cause personal injury.
- Never attempt to modify the carbide shank holder. Use the value for the depth of cut (ap) when the carbide shank is used.
Mill diameters D=8~12mm:ap<=0,05D.
Mill diameters D=16~32mm:ap<=0,1D.
- PCA12M grade is suitable for not so high speed machining.

Inserts

Face milling cutters

Square shoulder cutters

Slot cutters

Porcupine cutters

Specific applications and Sets

Profile milling



Characteristics:

High feed square insert cutters for peripheral milling ramp milling and drilling, pocket milling and copy milling. Precision type inserts are available for efficient machining in most materials.

Applications:

This copying, milling cutter works well on hard steels, alloyed steels, stainless steels, refractory casts and aluminium alloys. A general milling cutter for diversified manufacture that allows using it in only one pass (roughing and finishing) and it is recommended for machining centers.

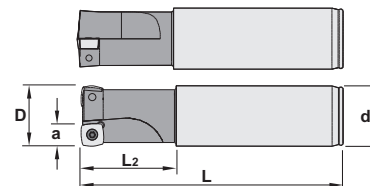
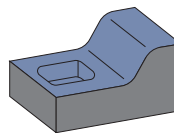
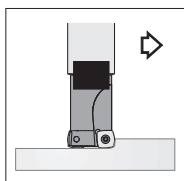

1635.00

Ref.		D	L	L2	d	a	Insert size	
1635.00.020	2	20	110	35	20	13	XDKW 090430	0,235
1635.00.025	2	25	110	35	25	13	XDKW 090430	0,350
1635.00.032	3	32	125	35	32	13	XDKW 090430	0,700

Ref.		
1635.00.020	1135	5510
1635.00.025	1135	5510
1635.00.032	1135	5510

XDKW		l	s	d	High feed.
Ref.	XDKW 090430	9,00	4,76	9,00	
For more information see page: A.23					
XDKW					



Characteristics:

High feed square insert cutters for peripheral milling ramp milling and drilling, pocket milling and copy milling. Precision type inserts are available for efficient machining in most materials.

Applications:

This copying, milling cutter works well on hard steels, alloyed steels, stainless steels, refractory casts and aluminium alloys. A general milling cutter for diversified manufacture that allows using it in only one pass (roughing and finishing) and it is recommended for machining centers.

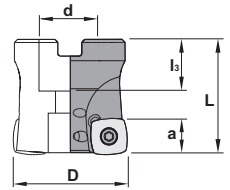
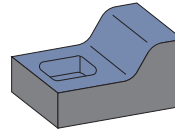
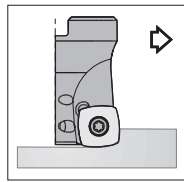

1645.90

Ref.		D	L	d	l3	a	Insert size	
1645.90.040	4	40	40	16	18	14	XDKW 120530	0,200
1645.90.050	5	50	50	22	20	14	XDKW 120530	0,300
1645.90.063	6	63	63	27	22	14	XDKW 120530	0,650
1645.90.080	7	80	80	27	22	14	XDKW 120530	1,150

Ref.			
1645.90.040	1240	5615	1058
1645.90.050	1240	5615	912,10
1645.90.063	1240	5615	912,12
1645.90.080	1240	5615	912,17

XDKW				High feed.
Ref.	l	s	d	
XDKW 120530	12,50	5,56	12,50	For more information see page: A.23
XDKW				

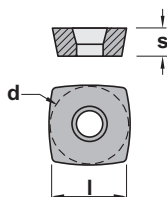

Inserts

Face milling cutters

Square shoulder cutters

Slot cutters

Porcupine cutters

Specific applications and Sets

Profile milling

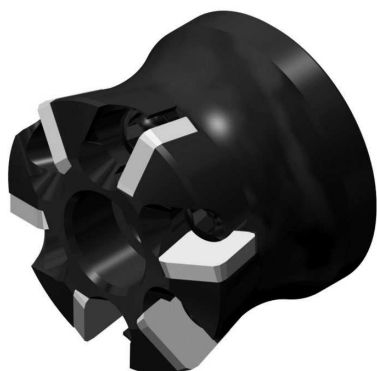

Characteristics:

High feed positive milling cutter with 15° entering angle. Its strong inserts accept high feed per teeth. The original fixing system from Canela allows a quick insert assembly and dismantling.

Applications:

This face milling cutter works well on steels, stainless steel, alloyed steels, cast iron and aluminium alloys. This general purpose milling cutter is recommended for C.N.C. machines.

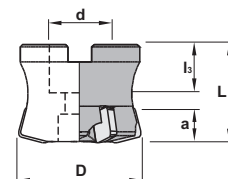
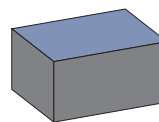
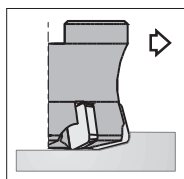

1440.90

Ref.		D	L	d	l3	a	Insert size	
1440.90.050	5	50	40	22	20	9	SP.. 1203..	0,300
1440.90.063	5	63	50	27	22	9	SP.. 1203..	0,700
1440.90.080	6	80	50	32	25	9	SP.. 1203..	1,100
1440.90.100	7	100	50	40	30	9	SP.. 1203..	1,800

Ref.						
1440.90.050	6226	1266	1630	5615	3012	912,11
1440.90.063	6226	1266	1630	5615	3012	912,12
1440.90.080	6226	1266	1630	5615	3012	912,17
1440.90.100	6226	1266	1630	5615	3012	912,20

SP..		l	s	d	Positive 11° clearance - Square inserts.
Ref.	SP.. 1203..	12,70	3,18	12,70	
For more information see page: A.19-20					

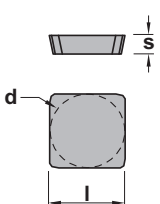

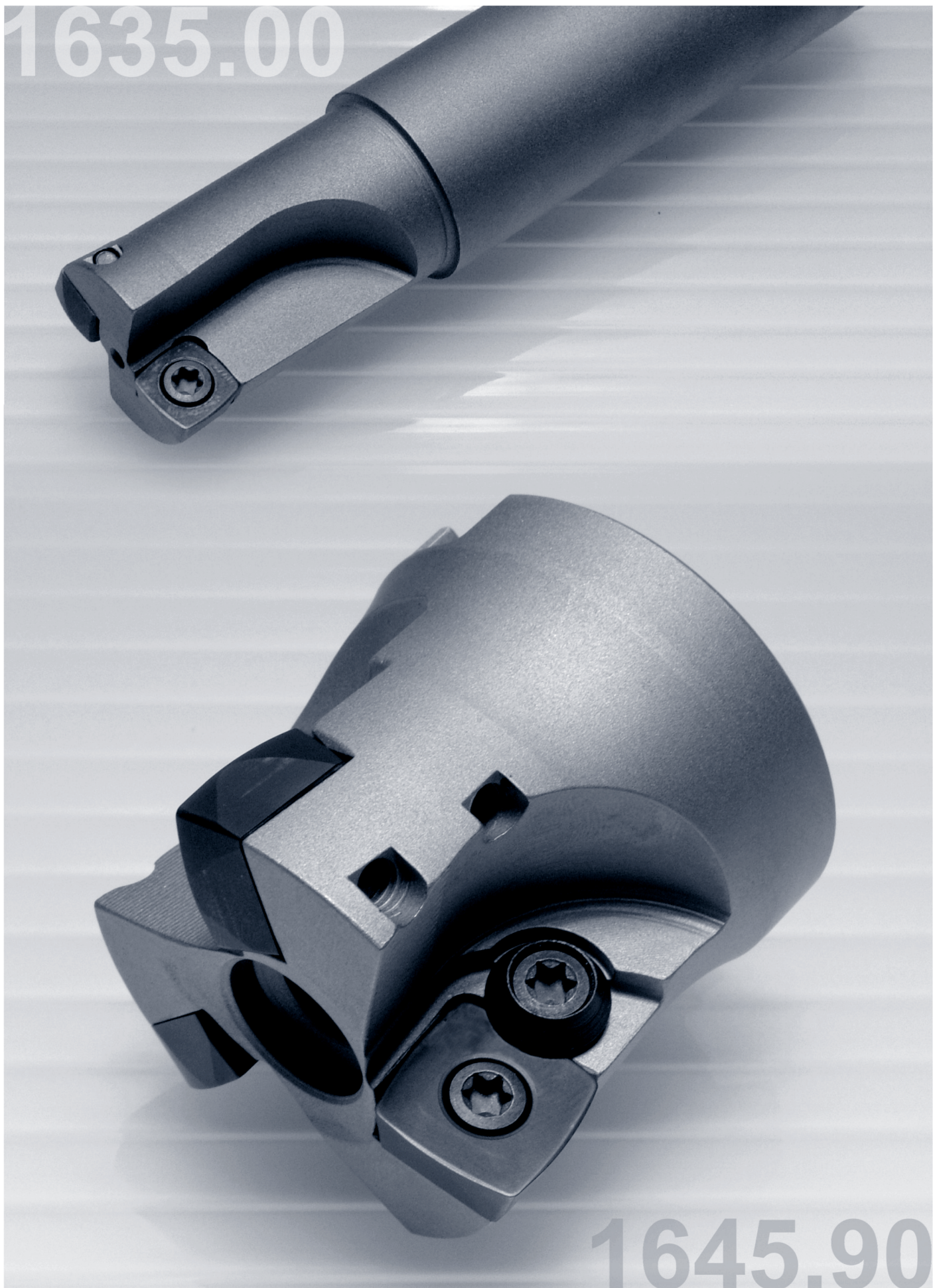

Profile milling

Solid carbide

Drills

Boring heads

Arbors and adaptors

Inserts

Face milling cutters

Square shoulder cutters

Slot cutters

Porcupine cutters

Specific applications and Sets

Profile milling

Processing by direct milling is also possible

Since the cutting flute does not extend to the center, there are limitations on the ramp angle and hole diameter, but as shown below, processing by direct milling without a pilot hole is possible for ramping and helical milling.

	Ramping		Helical milling			
	Ramp angle α		Helical hole diameter			
Tool diameter	$\varnothing 32$	$\varnothing 40$	$\varnothing 50$	$\varnothing 63$	$\varnothing 80$	$\varnothing 100$
Maximum ramp angle α	7°	4,5°	3°	1,7°	1°	1°
Hole diameter	$\varnothing 44-61$	$\varnothing 61-76$	$\varnothing 80-96$	$\varnothing 107-122$	$\varnothing 142-156$	$\varnothing 179-195$

Note -The ramp angle α should be set within the ranges listed above. Use at ramp angles of 1° or less recommended.
 -For hole diameters outside the ranges listed above, a pilot hole should be drilled before milling.

Method for defining conditions of insert tip programmatically

For roughing processing, please create a program with corner R values close to those shown as references below.

When corner R is set to 4,5

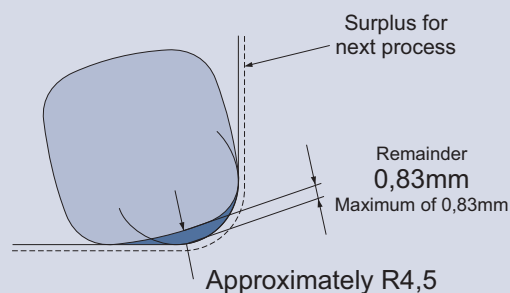

Normally, you should create a program with an input corner R of approximately 4,5. At an approximate input corner R of 4,5, there is no overcutting.

When corner R is set larger

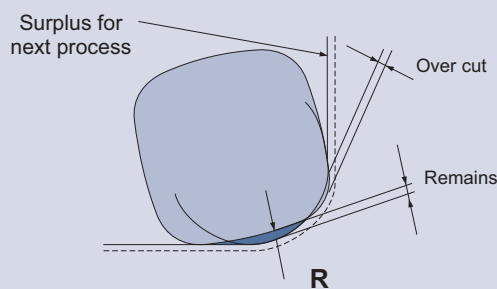

Although overcutting occurs when the approximate R is set to higher values, if the overcutting is within the surplus for the next process, there is no problem with the processing shape and the amount of remainder can be suppressed.

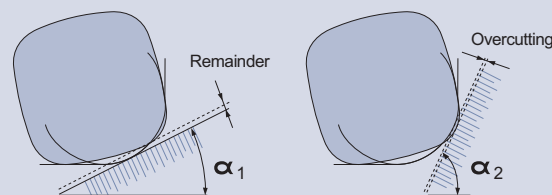
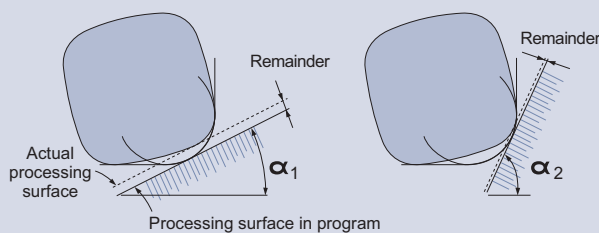

Approximate input corner R	R4,5	R5,1	R5,5	R5,8	R6,1	R6,4
Remainder	0,83 $\alpha_1=22,1^\circ$	0,66 $\alpha_1=20,3^\circ$	0,55 $\alpha_1=19^\circ$	0,47 $\alpha_1=17,9^\circ$	0,39 $\alpha_1=16,7^\circ$	0,32 $\alpha_1=15,4^\circ$
Overcutting	-	0,1 $\alpha_2=73,4^\circ$	0,2 $\alpha_2=67,7^\circ$	0,3 $\alpha_2=64,7^\circ$	0,4 $\alpha_2=62,3^\circ$	0,5 $\alpha_2=60,5^\circ$

Note

- Overcutting and remainder vary according to the processing shape. The values in the table above are maximum values.
 - The values of α shown are the slopes of the processing surfaces when overcutting and remainder are at their maximum respective values.

For example, when a program is created with an approximate R of 5,1:

Remainder of around 0,66mm is left when the slope of the processing surface is approximately 20,3°, and when the slope of the processing surface is approximately 73,4°, about 0,1mm of overcutting occurs. At areas with other slopes, the overcutting and remainder values are below these values.

Recommended cutting conditions

Material	Cutting speed Vc (m/min)	Per-flute feed rate fz (mm/tooth)	Ø 20 (2 flutes)			Ø 25 (2 flutes)			Ø 32 (3 flutes)			Ø 40 (4 flutes)		
			Rotation speed min. ⁻¹	Feed rate mm/min	Q value cm/min.	Rotation speed min. ⁻¹	Feed rate mm/min	Q value cm/min.	Rotation speed min. ⁻¹	Feed rate mm/min	Q value cm/min.	Rotation speed min. ⁻¹	Feed rate mm/min	Q value cm/min.
General Structural Steels (200 HB)	180-200	0,6-1,5	2860	3430	69	2290	2750	69	1790	5370	171	1430	6400	256
	Vc=180m/min fz=1,5mm/tooth ap=1,0mm ae=1,0D													
	90-150	0,6-2,0	1430	1720	34	1150	1380	34	895	2690	86	720	3240	130
	Vc=90m/min fz=1,5mm/tooth ap=1,0mm ae=1,0D													
Carbon Steels Alloy Steels (30 HRC)	180-200	0,6-1,5	2860	3430	69	2290	2750	69	1790	5370	171	1430	6400	256
	Vc=180m/min fz=1,5mm/tooth ap=1,0mm ae=1,0D													
	90-150	0,6-2,0	1430	1720	34	1150	1380	34	895	2690	86	720	3240	130
	Vc=90m/min fz=1,5mm/tooth ap=1,0mm ae=1,0D													
Carbon Steels Alloy Steels (30-45 HRC)	80-120	0,4-0,8	1430	1430	29	1150	1150	29	895	1430	45	720	1730	69
Vc=90m/min fz=0,8mm/tooth ap=1,0mm ae=1,0D														
Alloy Steels (45-50 HRC)	70-120	0,02-0,6	1590	630	6	1270	510	6	995	600	19	790	710	28
			Vc=100m/min fz=0,3mm/tooth ap=1,0mm ae=1,0D											
			1110	660	6	890	530	6	700	280	9	550	330	13
			Vc=70m/min fz=0,2mm/tooth ap=0,5mm ae=1,0D											
Alloy Steels (50-55 HRC)	70-100	0,05-0,2	1110	440	4	890	360	4	700	280	5	550	330	7
Vc=70m/min fz=0,2mm/tooth ap=1,0mm ae=1,0D														
Alloy Steels (55-60 HRC)	50-100		790	80	0,8	630	63	0,8	500	50	0,8	400	60	1
Vc=50m/min fz=0,05mm/tooth ap=0,5mm ae=1,0D														
Cast Iron	180-200	0,8-2,0	2860	4580	92	2290	3670	92	1790	7160	344	1430	8580	515
	Vc=180m/min fz=2,0mm/tooth ap=1,5mm ae=1,0D													
	90-150		1430	2290	57	1150	1840	58	895	3580	172	720	4320	259
	Vc=90m/min fz=2,0mm/tooth ap=1,5mm ae=1,0D													

Material	Cutting speed Vc (m/min)	Per-flute feed rate fz (mm/tooth)	Ø 50 (5 flutes)			Ø 63 (6 flutes)			Ø 80 (5 flutes)			Ø 100 (7 flutes)		
			Rotation speed min. ⁻¹	Feed rate mm/min	Q value cm/min.	Rotation speed min. ⁻¹	Feed rate mm/min	Q value cm/min.	Rotation speed min. ⁻¹	Feed rate mm/min	Q value cm/min.	Rotation speed min. ⁻¹	Feed rate mm/min	Q value cm/min.
General Structural Steels (200 HB)	180-200	0,6-1,5	1150	6900	510	910	5500	520	720	5400	650	570	5130	770
	Vc=180m/min fz=1,5mm/tooth ap=1,5mm ae=1,0D													
	90-150	0,6-2,0	570	3420	257	455	2730	258	360	2700	325	290	2610	390
	Vc=90m/min fz=1,5mm/tooth ap=1,5mm ae=1,0D													
Carbon Steels Alloy Steels (30 HRC)	180-200	0,6-1,5	1150	6900	510	910	5500	520	720	5400	650	570	5130	770
	Vc=180m/min fz=1,5mm/tooth ap=1,5mm ae=1,0D													
	90-150	0,6-2,0	570	3420	257	455	2730	258	360	2700	325	290	2610	390
	Vc=90m/min fz=1,5mm/tooth ap=1,5mm ae=1,0D													
Carbon Steels Alloy Steels (30-45 HRC)	80-120	0,4-0,8	570	1820	130	455	1450	140	360	1440	170	290	1400	210
Vc=90m/min fz=0,8mm/tooth ap=1,5mm ae=1,0D														
Alloy Steels (45-50 HRC)	70-120	0,02-0,6	630	760	38	500	600	38	400	600	48	320	576	58
			Vc=100m/min fz=0,3mm/tooth ap=1,0mm ae=1,0D											
			440	360	18	350	280	18	280	280	22	220	260	26
			Vc=70m/min fz=0,2mm/tooth ap=1,0mm ae=1,0D											
Alloy Steels (50-55 HRC)	70-100	0,05-0,2	440	350	9	350	280	9	270	270	11	220	260	13
Vc=70m/min fz=0,2mm/tooth ap=0,5mm ae=1,0D														
Alloy Steels (55-60 HRC)	50-100		310	62	1,5	250	50	1,5	200	50	2,0	160	48	2,4
Vc=50m/min fz=0,05mm/tooth ap=0,5mm ae=1,0D														
Cast Iron	180-200	0,8-2,0	1150	9200	920	910	7280	920	720	7200	1150	570	6840	1370
	Vc=180m/min fz=2,0mm/tooth ap=2,0mm ae=1,0D													
	90-150		570	4560	456	455	3640	459	360	3600	576	290	3840	696
	Vc=90m/min fz=2,0mm/tooth ap=2,0mm ae=1,0D													

Note

- Select the best cutting condition when working, referring to above list.
(If the overhang is 3D or less, the recommended cutting speed is Vc=180-200m/min; 3D or more: Vc=90-130m/min.)

- Thick and heavy chips are generated by using this tool. Be sure to remove them with air blow in order to avoid any breakage by blocking with chips.
The recommended method is "Spindle center through" when blowing air. (Pay attention when removing chips in cavity work with the machining center <vertical type>.)

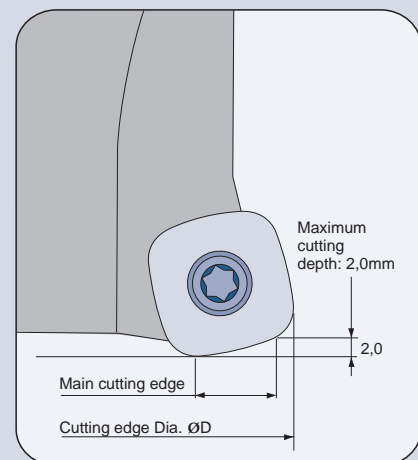

Inserts

Face milling cutters

Square shoulder cutters

Slot cutters

Porcupine cutters

Specific applications and Sets

Profile milling



Characteristics:

Round insert end mills for slot milling, peripheral milling, ramp milling and drilling, pocket milling and copy milling. Precision type inserts are available for efficient machining in most materials.

Applications:

This copying milling cutter works well on hard steels, alloyed steels, stainless steels, refractory casts and aluminium alloys. A general milling cutter for diversified manufacture that allows using it in only one pass (roughing and finishing) and it is recommended for conventional milling machines and machining centers.

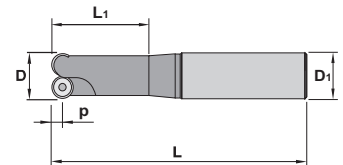
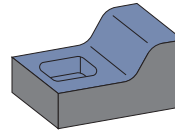
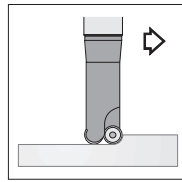

55_5

Ref.			D	L	D1	L1	p	Insert size	
5525.00.015	2		15	100	20	40	3,5	RD.. 0702M0	0,180
5525.01.015	2		15	150	20	40	3,5	RD.. 0702M0	0,300
5525.00.016	2		16	100	20	40	3,5	RD.. 0702M0	0,185
5525.01.016	2		16	150	20	40	3,5	RD.. 0702M0	0,310
5535.00.020	2		20	100	20	40	5,0	RD.. 1003M0	0,220
5535.01.020	2		20	150	20	40	5,0	RD.. 1003M0	0,340
5545.00.025	2		25	125	25	50	6,0	RD.. 12T3M0	0,460
5545.01.025	2		25	180	25	60	6,0	RD.. 12T3M0	0,670
5545.00.032	3		32	125	32	50	6,0	RD.. 12T3M0	0,740
5545.01.032	3		32	180	32	60	6,0	RD.. 12T3M0	1,080
5555.01.032	2		32	180	32	60	8,0	RD.. 1604M0	1,080



Ref.			
5525.00.015	1425		5507
5525.01.015	1425		5507
5525.00.016	1425		5507
5525.01.016	1425		5507
5535.00.020	1435		5515
5535.01.020	1435		5515
5545.00.025	1435		5515
5545.01.025	1435		5515
5545.00.032	1435		5515
5545.01.032	1435		5515
5555.01.032	1245		5515

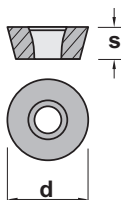

Ref.	RD..	l	s	d
RD.. 0702M0	-	-	2,38	7,00
RD.. 1003M0	-	-	3,18	10,00
RD.. 12T3M0	-	-	3,97	12,00
RD.. 1604M0	-	-	4,76	16,00

Positive 15° clearance - Round insert.

For more information see page: A.15

RDHW

RDMT

RDMW





Shanks page: K.45 - K.46

Characteristics:

Round insert end mills for slot milling, peripheral milling, ramp milling and drilling, pocket milling and copy milling. Precision type inserts are available for efficient machining in most materials. Milling cutter equipped with modular shank.

Applications:

This copying milling cutter works well on hard steels, alloyed steels, stainless steels, refractory casts and aluminium alloys. A general milling cutter for diversified manufacture that allows using it in only one pass (roughing and finishing) and it is recommended for conventional milling machines and machining centers.

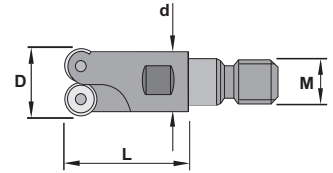
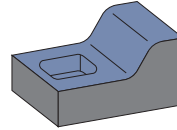
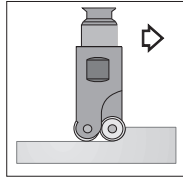

55_5.06

Ref.		D	L	M	d	Insert size	
5525.06.016	2	16	23	M8	14	RD.. 0702..	0,030
5535.06.020	2	20	30	M10	18	RD.. 1003..	0,060
5535.06.025	3	25	35	M12	21	RD.. 1003..	0,095
5535.06.035	4	35	43	M16	29	RD.. 1003..	0,225
5535.06.042	5	42	43	M16	29	RD.. 1003..	0,320
5545.06.025	2	25	43	M12	21	RD.. 12T3..	0,095
5545.06.032	3	32	43	M16	29	RD.. 12T3..	0,230
5545.06.035	3	35	43	M16	29	RD.. 12T3..	0,250
5545.06.042	4	42	43	M16	29	RD.. 12T3..	0,320
5545.06.042Z=5	5	42	43	M16	29	RD.. 12T3..	0,320
5555.06.032	2	32	43	M16	29	RD.. 1604..	0,250

Ref.		
5525.06.016	1425	5507
5535.06.020	1435	5515
5535.06.025	1435	5515
5535.06.035	1435	5515
5535.06.042	1435	5515
5545.06.025	1435	5515
5545.06.032	1435	5515
5545.06.035	1435	5515
5545.06.042	1435	5515
5545.06.042Z=5	1435	5515
5555.06.032	1245	5515

		RD..	l	s	d	Positive 15° clearance - Round insert.
Ref.		RD..0702M0	-	2,38	7,00	
		RD..1003M0	-	3,18	10,00	
		RD..12T3M0	-	3,97	12,00	
		RD..1604M0	-	4,76	16,00	
		RDHW	RDMT	RDMW		

For more information see page: A.15

Inserts

Face milling cutters

Square shoulder cutters

Slot cutters

Porcupine cutters

Specific applications and Sets

Profile milling



Characteristics:

Round insert end mills for slot milling, peripheral milling, ramp milling and drilling, pocket milling and copy milling. Precision type inserts are available for efficient machining in most materials.

Applications:

This copying milling cutter works well on hard steels, alloyed steels, stainless steels, refractory casts and aluminium alloys. A general milling cutter for diversified manufacture that allows using it in only one pass (roughing and finishing) and it is recommended for conventional milling machines and machining centers.

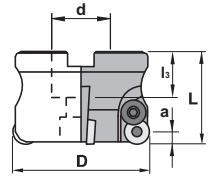
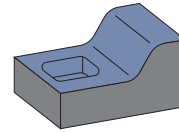
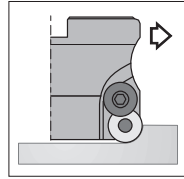

55⁴/₅ 5.90

Ref.			D	L	d	l3	a	Insert size	
5545.90.052	5		52	50	22	20	6	RD.. 12T3..	0,450
5545.90.066	6		66	50	27	22	6	RD.. 12T3..	0,770
5545.90.080	7		80	50	27	22	6	RD.. 12T3..	1,200
5555.90.052	4		52	50	22	20	8	RD.. 1604..	0,350
5555.90.066	5		66	50	27	22	8	RD.. 1604..	0,700
5555.90.080	6		80	50	27	22	8	RD.. 1604..	1,050
5555.90.100	7		100	55	32	25	8	RD.. 1604..	1,800
5555.90.125	8		125	55	40	30	8	RD.. 1604..	3,500
5555.90.160	9		160	55	40	30	8	RD.. 1604..	5,600

Ref.				
5545.90.052	1235	2009	912,10	5615
5545.90.066	1235	2009	912,12	5615
5545.90.080	1235	2009	912,12	5615
5555.90.052	1245	2010	912,10	5615
5555.90.066	1245	2010	912,12	5615
5555.90.080	1245	2010	912,12	5615
5555.90.100	1245	2010	912,17	5615
5555.90.125	1245	2010	-	5615
5555.90.160	1245	2010	912,52	5615

Ref.	RD..	l	s	d	Positive 15° clearance - Round insert.
RD.. 12T3M0		-	3,97	12,00	
RD.. 1604M0		-	4,76	16,00	
	RDHW	RDMT	RDMW		

For more information see page: A.15



Characteristics:

Round insert end mills for slot milling, peripheral milling, ramp milling and drilling, pocket milling and copy milling. Precision type inserts are available for efficient machining in most materials.

Applications:

This copying milling cutter works well on hard steels, alloyed steels, stainless steels, refractory casts and aluminium alloys. A general milling cutter for diversified manufacture that allows using it in only one pass (roughing and finishing) and it is recommended for conventional milling machines and machining centers.

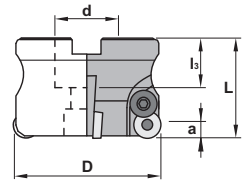
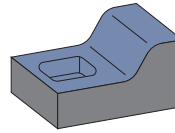
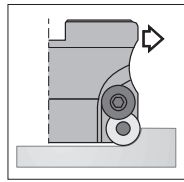

5549.90

Ref.		D	L	d	l3	a	Insert size	
5549.90.040	3	40	40	16	18	6	RPM.. 1204M0	0,200
5549.90.050	4	50	40	22	20	6	RPM.. 1204M0	0,300
5549.90.063	5	63	50	27	22	6	RPM.. 1204M0	0,650
5549.90.080	6	80	50	32	25	6	RPM.. 1204M0	1,150
5549.90.100	7	100	50	40	30	6	RPM.. 1204M0	1,750
5549.90.125	7	125	63	40	30	6	RPM.. 1204M0	3,100
5549.90.160	8	160	63	40	30	6	RPM.. 1204M0	4,100

Ref.						
5549.90.040	1025	5003	1240	5615	1058	-
5549.90.050	1025	5003	1240	5615	912,10	-
5549.90.063	1025	5003	1240	5615	912,12	-
5549.90.080	1025	5003	1240	5615	912,17	-
5549.90.100	1025	5003	1240	5615	912,20	-
5549.90.125	1025	5003	1240	5615	-	-
5549.90.160	1025	5003	1240	5615	912,52	40

	RPM..				Positive 11° clearance - Round inserts.
	Ref.	l	s	d	
	RPM.. 1204M0	-	4,76	12,00	
	RPMT	RPMW			

For more information see page: A.15

Recommended cutting conditions

Material	m/min Cutting Speed	mm/tooth Feed rate	Ø12 - Ø20			Ø24 - Ø25			Ø32 - Ø35		
			min ¹	mm/min	cm ³ /min	min ¹	mm/min	cm ³ /min	min ¹	mm/min	cm ³ /min
Mild Steels (200 HB)	150-250	0,3-0,8	3980	3180	28,6	3180	2540	28,6	2490	2990	43,1
			Vc=250m/min fz=0,4mm/tooth ap=1,5mm ae=0,3D								
			3980	3180	47,7	3180	2540	47,6	2490	2990	71,8
Carbon Steels Alloy Steels (30 HRC)	120-230	0,3-0,8	3180	2540	22,9	2550	2040	23	1990	2390	34,4
			Vc=200m/min fz=0,4mm/tooth ap=1,5mm ae=0,3D								
			3180	2540	38,1	2550	2040	38,3	1990	2390	57,4
Carbon Steels Alloy Steels (30-40 HRC)	100-200	0,2-0,6	2390	960	8,6	1910	760	8,6	1490	890	12,8
			Vc=150m/min fz=0,2mm/tooth ap=1,5mm ae=0,3D								
			2390	1430	21,5	1910	1150	21,6	1490	1340	32,2
Carbon Steels Alloy Steels (40-45 HRC)	60-150	0,15-0,3	1590	480	2,9	1270	380	2,9	990	450	4,3
			Vc=100m/min fz=0,15mm/tooth ap=1mm ae=0,3D								
			1590	640	6,4	1270	510	6,4	990	590	9,4
Carbon Steels Alloy Steels (45-50 HRC)	60-100	0,15-0,3	1270	380	2,3	1020	310	2,3	800	360	3,5
			Vc=80m/min fz=0,15mm/tooth ap=1mm ae=0,3D								
			1270	380	3,8	1020	310	3,9	800	360	5,8
Alloy Steels (50-60 HRC)	50-100	0,05-0,2	1110	220	1,3	890	170	1,2	690	200	1,9
			Vc=70m/min fz=0,1mm/tooth ap=1mm ae=0,3D								
			1110	220	2,2	890	170	2,1	690	200	3,2
Stainless Steels	150-240	0,2-0,8	3180	1590	14,3	2550	1280	14,4	1990	1490	21,5
			Vc=200m/min fz=0,25mm/tooth ap=1,5mm ae=0,3D								
			2860	1716	25,7	2290	1370	25,7	1790	1610	38,6
Cast Iron	100-220	0,3-1,0	2860	2290	20,6	2290	1830	20,6	1790	2150	31
			Vc=180m/min fz=0,4mm/tooth ap=1,5mm ae=0,3D								
			2860	2860	42,9	2290	2290	42,9	1790	2690	64,6
Vc=180m/min fz=0,5mm/tooth ap=1,5mm ae=0,5D											

Material	Ø40 - Ø42 (R6)			Ø50 - Ø52 (R6)			Ø40 - Ø42 (R8)			Ø50 - Ø52 (R8)		
	min ¹	mm/min	cm ³ /min	min ¹	mm/min	cm ³ /min	min ¹	mm/min	cm ³ /min	min ¹	mm/min	cm ³ /min
Mild Steels (200 HB)	1990	2990	71,8	1590	3180	95,4	1990	1990	47,8	1590	2390	71,7
	Vc=250m/min fz=0,5mm/tooth ap=2mm ae=0,3D											
	1990	4780	191,2	1590	5090	254,5	1990	3180	159	1590	3820	238,8
Carbon Steels Alloy Steels (30 HRC)	1590	1910	45,8	1270	2030	60,9	1590	1270	30,5	1270	1520	45,6
	Vc=200m/min fz=0,4mm/tooth ap=2mm ae=0,3D											
	1590	2860	114,4	1270	3050	152,5	1590	1910	95,5	1270	2290	143,1
Carbon Steels Alloy Steels (30-40 HRC)	1190	710	17	960	770	23,1	1190	480	11,5	960	580	17,4
	Vc=150m/min fz=0,2mm/tooth ap=2mm ae=0,3D											
	1190	1070	42,8	960	1150	57,5	1190	950	47,5	960	1150	71,9
Carbon Steels Alloy Steels (40-45 HRC)	800	360	6,5	640	380	8,6	800	240	4,3	640	290	6,5
	Vc=100m/min fz=0,15mm/tooth ap=1,5mm ae=0,3D											
	800	480	14,4	640	510	19,1	800	320	12,8	640	380	19
Carbon Steels Alloy Steels (45-50 HRC)	640	290	3,5	510	310	4,7	640	220	4	510	260	5,9
	Vc=80m/min fz=0,17mm/tooth ap=1mm ae=0,5D											
	640	330	6,6	510	350	8,8	640	260	7,8	510	310	11,6
Alloy Steels (50-60 HRC)	550	160	1,9	440	170	2,5	550	110	1,3	440	130	1,9
	Vc=70m/min fz=0,1mm/tooth ap=1mm ae=0,3D											
	550	160	3,2	440	170	4,2	550	110	2,2	440	130	3,2
Stainless Steels	1590	1430	34,3	1270	1520	45,6	1590	950	22,8	1270	1140	34,2
	Vc=200m/min fz=0,3mm/tooth ap=2mm ae=0,3D											
	1430	2150	86	1150	2300	115	1430	1720	86	1150	2070	129,4
Cast Iron	1430	3430	137,2	1150	3680	184	1430	2290	114,5	1150	2760	172,5
	Vc=180m/min fz=0,5mm/tooth ap=2mm ae=0,3D											
	Vc=180m/min fz=0,8mm/tooth ap=2mm ae=0,5D											

Note

-In this table, cutting conditions indicate regular type conditions for flank wear to be 0,3mm in 30 minutes.

-The following formula shows the chip removal volume (Q) per unit time.

$$Q(\text{cm}^3/\text{min}) = \text{ap}(\text{mm}) \times \text{ae}(\text{mm}) \times \text{Vf}(\text{mm}/\text{min}) / 1000$$

-In the case of slotting, feed speed could be down to 70% of the whole.

-This table shows starting points of general cutting conditions. Please adjust according to rigidity of machine tools, tooling, conditions of work-pieces and so on.

-In steel exceeding 60HRC, such as dice steel between the colds, please set the sending (fz) value per one edge about 1/2.

Recommended cutting conditions

Material	m/min Cutting Speed	mm/tooth Feed rate	Ø63 (R6)			Ø80 (R6)			Ø100 (R6)		
			min ⁻¹	mm/min	cm ³ /min	min ⁻¹	mm/min	cm ³ /min	min ⁻¹	mm/min	cm ³ /min
Mild Steels (200 HB)	150-250	0,3-0,8	3780	142,9	-	-	-	-	-	-	-
			Vc=250m/min fz=0,5mm/tooth ap=2mm ae=0,3D								
			1260	6050	381,2	1000	4800	384	800	3200	320
Carbon Steels Alloy Steels (30 HRC)	120-230	0,3-0,8	1010	2420	91,5	-	-	-	-	-	-
			Vc=200m/min fz=0,4mm/tooth ap=2mm ae=0,3D								
			1010	3640	229,3	800	2880	230,4	640	1920	192
Carbon Steels Alloy Steels (30-40 HRC)	100-200	0,2-0,6	760	910	34,4	-	-	-	-	-	-
			Vc=150m/min fz=0,2mm/tooth ap=2mm ae=0,3D								
			760	1370	86,3	600	1080	86,4	480	720	72
Carbon Steels Alloy Steels (40-45 HRC)	60-150	0,15-0,3	510	460	13	-	-	-	-	-	-
			Vc=100m/min fz=0,15mm/tooth ap=1,5mm ae=0,3D								
			510	610	28,8	400	480	28,8	320	320	24
Carbon Steels Alloy Steels (45-50 HRC)	60-100	0,15-0,3	400	360	6,8	-	-	-	-	-	-
			Vc=80m/min fz=0,15mm/tooth ap=1mm ae=0,3D								
			400	410	12,9	320	330	13,2	250	210	10,5
Alloy Steels (50-60 HRC)	50-100	0,05-0,2	350	210	3,9	270	160	3,8	220	110	3,3
			Vc=70m/min fz=0,1mm/tooth ap=1mm ae=0,3D								
			350	210	6,6	270	160	6,4	220	110	5,5
Stainless Steels	150-240	0,2-0,8	1010	1820	68,8	-	-	-	-	-	-
			Vc=200m/min fz=0,3mm/tooth ap=2mm ae=0,3D								
			910	2730	172	720	2160	172,8	570	1430	143
Cast Iron	100-220	0,3-1,0	910	2730	103,2	-	-	-	-	-	-
			Vc=180m/min fz=0,5mm/tooth ap=2mm ae=0,3D								
			910	4370	275,3	720	3460	276,8	570	2280	228
Vc=180m/min fz=0,8mm/tooth ap=2mm ae=0,5D											

Field Data

Ramping, Helical Milling, Feeding toward Z-AXIS

There are restrictions to Ramp angle (α) and cutting depth (g) toward Z-axis because of designs of cutting edge.

Ramping

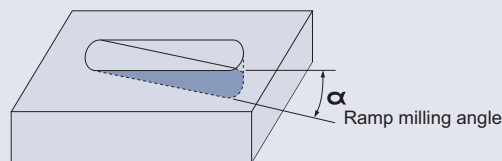

Helical milling

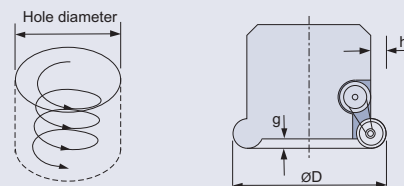

ØD	Ø40	Ø50 - Ø52	Ø63 - Ø66	Ø80	Ø100	Ø125 - Ø160
Recommended α	Below 3 degrees					Below 2 degrees
h	2,5	2,5	2,5	2,5	2,5	2,5
g	3,7	3,3	5,5	5,5	5,5	5,5
Helical hole diameter	60-78	77-100	101-124	135-158	175-198	248-255

Note

-Chips may be shattered. The wearing of safety glasses and the guard are required in the vicinity of machining.

Inserts

Face milling cutters

Square shoulder cutters

Slot cutters

Porcupine cutters

Specific applications and Sets

Profile milling



Shanks page: K.45 - K.48

Characteristics:

General application end mills for slot milling, peripheral milling, ramp milling and drilling, pocket milling and copy milling. Precision type inserts are available for efficient machining aluminium alloys.

Applications:

Aluminium plastics and exotic materials machining.

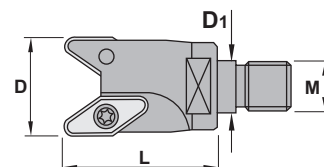
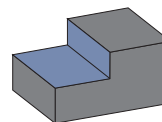
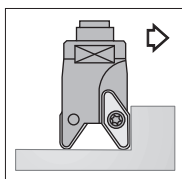

0344.06

Ref.		D	L	M	D1	Insert size	
0344.06.015	2	15	35	M8	8,5	VCGT 1103..	0,040
0344.06.020	2	20	35	M10	10,5	VCGT 1103..	0,070
0344.06.025	2	25	50	M12	12,5	VCGT 1604..	0,110
0344.06.032	2	32	50	M16	17,0	VCGT 2205..	0,240
0344.06.042	3	42	50	M16	17,0	VCGT 2205..	0,400

Ref.		
0344.06.015	1225	5507
0344.06.020	1225	5507
0344.06.025	1240	5515
0344.06.032	1250	5520
0344.06.042	1250	5520

VCGT		l	s	d	Positive 7° clearance - 35° rhombic inserts
Ref.	VCGT 1103..	11,00	3,18	6,35	
VCGT 1604..	16,50	4,76	9,52		
VCGT 2205..	22,10	5,56	12,70		
For more information see page: A.22					
VCGT-AL	VCGT-AP				

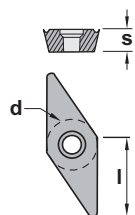



Characteristics:

General application bottom cutter for slot milling, peripheral milling, ramp milling and drilling, pocket milling and copy milling. Precision type inserts are available for efficient machining aluminium alloys.

Applications:

Aluminium plastics and exotic materials machining.

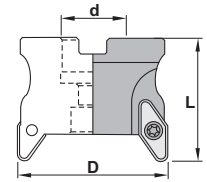
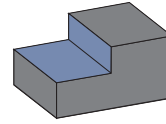
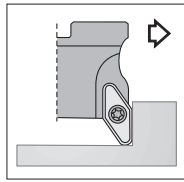

0344.90

Ref.		D	d	L	Insert size	
0344.90.042	3	42	16	55	VCGT 2205..	0,180
0344.90.052	3	52	22	55	VCGT 2205..	0,350
0344.90.066	4	66	27	55	VCGT 2205..	0,800
0344.90.080	5	80	27	55	VCGT 2205..	1,150

Ref.		
0344.90.042	1250	5520
0344.90.052	1250	5520
0344.90.066	1250	5520
0344.90.080	1250	5520

VCGT		l	s	d	Positive 7° clearance - 35° rhombic inserts
Ref.	VCGT 2205..	22,10	5,56	12,70	
For more information see page: A.22					
	VCGT-AL				
	VCGT-AP				

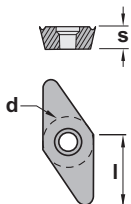

Inserts

Face milling cutters

Square shoulder cutters

Slot cutters

Porcupine cutters

Specific applications and Sets

Profile milling

Recommended cutting conditions

Material		Cutting Speed	
		ZR 10 Vc (mm/min)	KM 15 Vc (mm/min)
Aluminium alloys	Rm < 280 N/mm ²	1500	1000
	Rm < 280 N/mm ²	1000	800
Copper alloys	Long chipping	300	250
Thermoplastics			300
Aluminium alloys	Si < 12 %	100	800
	Si ≥ 12 %	200	
Copper alloys	Short chipping	500	400
Magnesium alloys			400
Duroplastics		200	150

Maximum feed per tooth fz (mm/z) in mm		
VCGT 1103..	VCGT 1604..	VCGT 2205..
0,25	0,35	0,5
0,2	0,3	0,4

Further application recommendations

Pocket milling and axial plunging

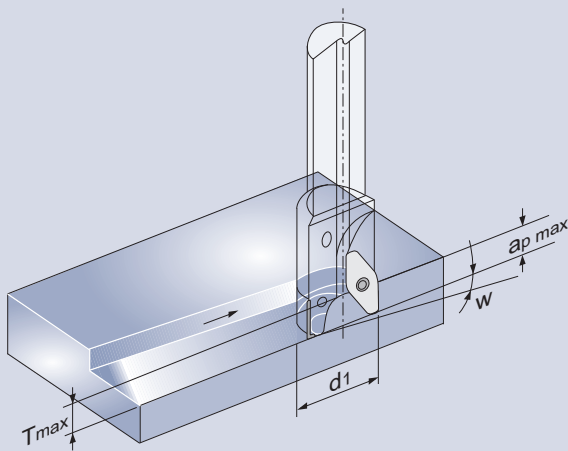

Circular milling

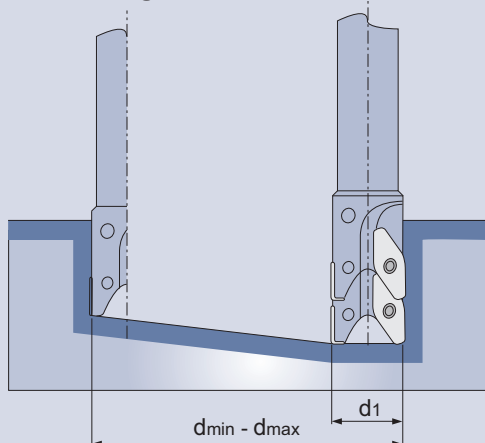

Helix angle W1 max and internal depth of cut Tmax	VCGT 110304-ALM	VCGT 160412-ALM	VCGT 220530-ALM
	ap max	10	13,5
T max	6	8	9
W1 max degree			
15			
20	25		
25		24	
32			22
42			15
52			12
66			9
80			7

d1 mm	dmin mm	dmax mm
15	15	15
20	20	20
25	25	25
32	32	32
42	42	42
52	52	52
66	66	66
80	80	80

0344.90

General application bottom cutter for slot milling, peripheral milling, ramp milling and drilling, pocket milling and copy milling. Precision type inserts are available for efficient machining aluminium alloys.

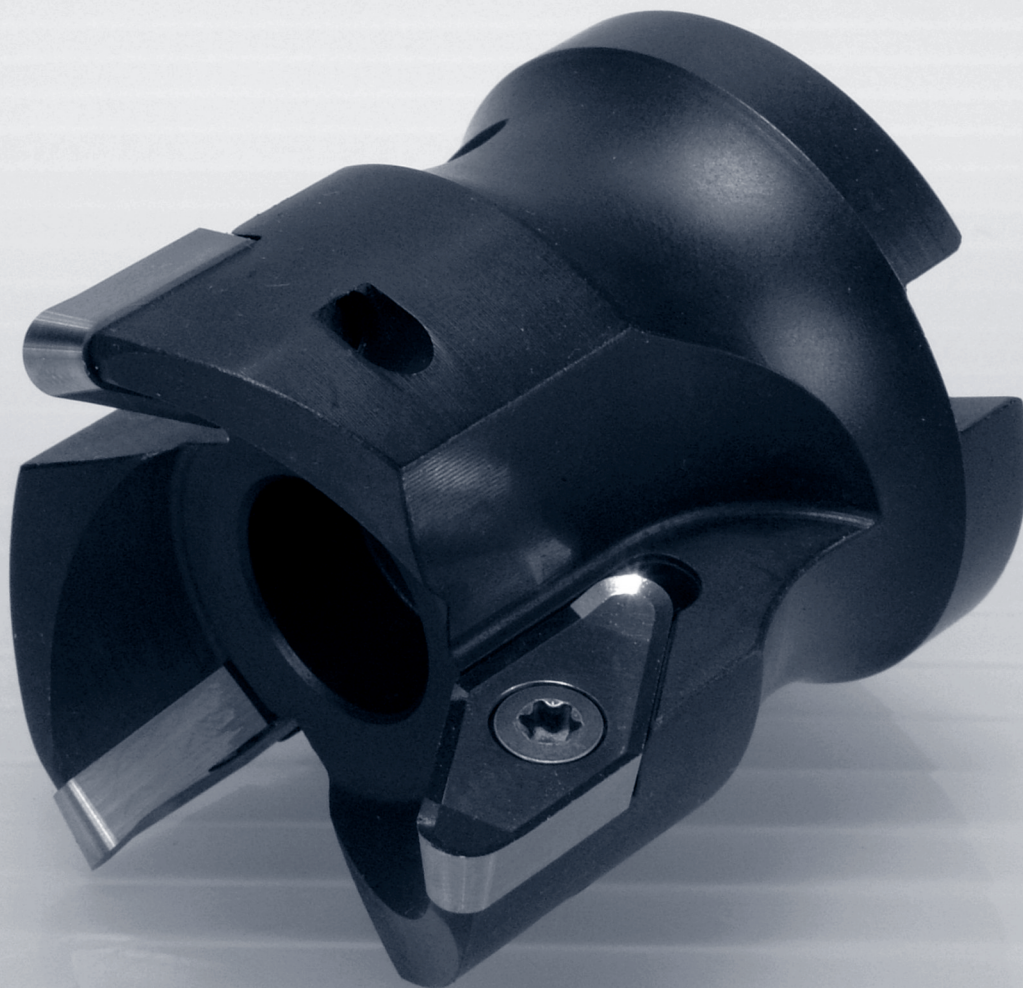

Profile milling

Solid carbide

Drills

Boring heads

Arbors and adaptors