

Cartridges

Inserts

General turning

Aluminium
wheel turning

Automatic lathes

Ceramic tools

Parting and
grooving

Threading

Drills

Cartridges

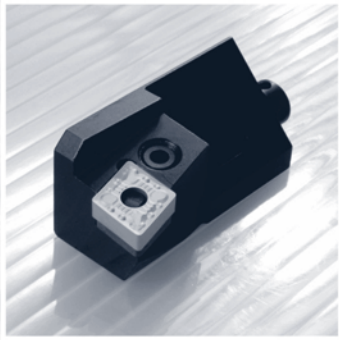

Cartridges

Code key	J.02
Applications	J.03
Top clamp cartridges	J.04
Lever lock cartridges	J.08
Center screw cartridges	J.13

P	C	L	N	R	16	CA	-	12
1	2	3	4	5	6	7		8

1

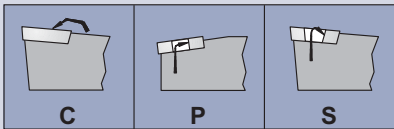

3

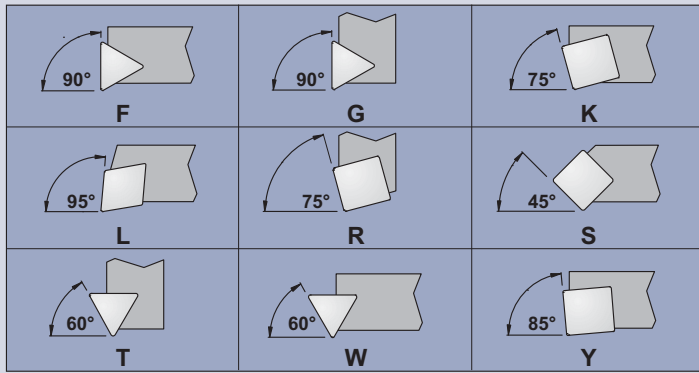

2

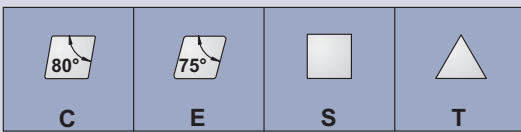

4

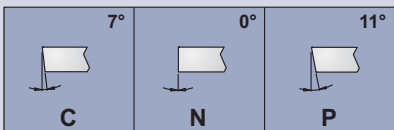

5

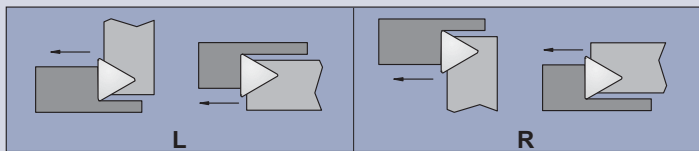

6

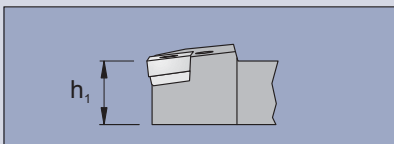

7

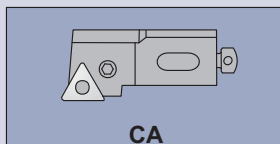

8

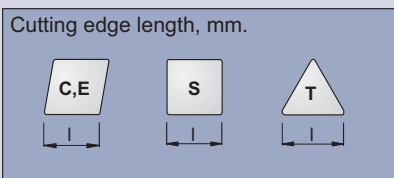

Inserts

General turning

Aluminium wheel turning

Automatic lathes

Ceramic tools



Parting and grooving

Threading

Drills

Cartridges

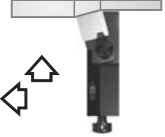
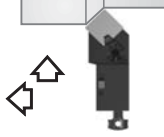
Top clamp cartridges

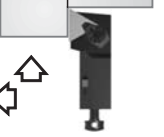
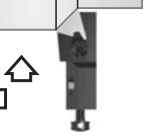
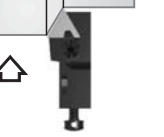
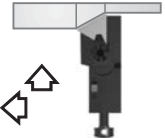
<p>CSKP 75°</p>  <p>Page J.04 SP.. 0903.. SP.. 1203..</p>	<p>CSSP 45°</p>  <p>Page J.04 SP.. 0903.. SP.. 1203..</p>	<p>CTFP 90°</p>  <p>Page J.05 TP.. 1103.. TP.. 1603..</p>	<p>CTGP 90°</p>  <p>Page J.05 TP.. 1103.. TP.. 1603..</p>	<p>CTSP 45°</p>  <p>Page J.06 TP.. 1103.. TP.. 1603..</p>	<p>CTTP 60°</p>  <p>Page J.06 TP.. 1103.. TP.. 1603..</p>
<p>CTWP 30°</p>  <p>Page J.07 TP.. 1103.. TP.. 1603..</p>					

Lever lock cartridges

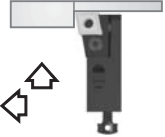
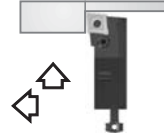
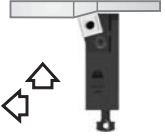
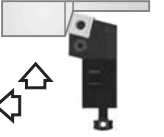
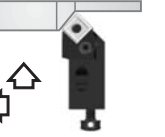
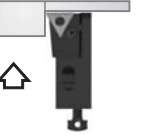
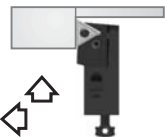
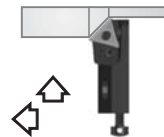
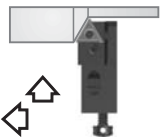
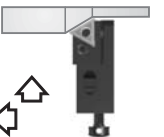
<p>PCFN 90°</p>  <p>Page J.08 CN.. 1204.. CN.. 1606..</p>	<p>PCLN 95°</p>  <p>Page J.08 CN.. 1204.. CN.. 1606..</p>	<p>PSKN 75°</p>  <p>Page J.09 SNM.. 1204.. SNM.. 1506..</p>	<p>PSRN 75°</p>  <p>Page J.09 SNM.. 1204..</p>	<p>PSSN 45°</p>  <p>Page J.10 SNM.. 1204..</p>	<p>PTFN 90°</p>  <p>Page J.10 TNM.. 1604.. TNM.. 2204..</p>
<p>PTGN 90°</p>  <p>Page J.11 TNM.. 1604.. TNM.. 2204..</p>	<p>PTSN 45°</p>  <p>Page J.11 TNM.. 1604.. TNM.. 2204..</p>	<p>PTTN 60°</p>  <p>Page J.12 TNM.. 1604.. TNM.. 2204..</p>	<p>PTWN 30°</p>  <p>Page J.12 TNM.. 1604.. TNM.. 2204..</p>		

Center screw cartridges

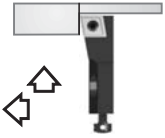
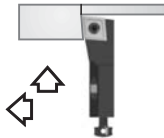
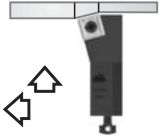
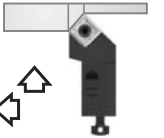
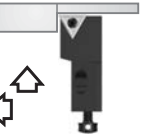
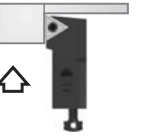
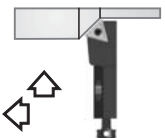
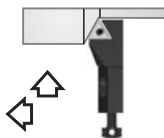
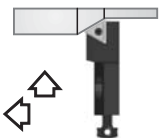
<p>SCFC 90°</p>  <p>Page J.13 CC.. 0602.. CC.. 09T3.. CC.. 1204..</p>	<p>SCLC 95°</p>  <p>Page J.13 CC.. 0602.. CC.. 09T3.. CC.. 1204..</p>	<p>SSKC 75°</p>  <p>Page J.14 SC.. 09T3.. SC.. 1204..</p>	<p>SSSC 45°</p>  <p>Page J.14 SC.. 09T3.. SC.. 1204..</p>	<p>STFC 90°</p>  <p>Page J.15 TC.. 0902.. TC.. 1102.. TC.. 16T3..</p>	<p>STGC 90°</p>  <p>Page J.15 TC.. 1102.. TC.. 16T3..</p>
<p>STSC 45°</p>  <p>Page J.16 TC.. 0902.. TC.. 1102.. TC.. 16T3..</p>	<p>STTC 60°</p>  <p>Page J.16 TC.. 0902.. TC.. 1102.. TC.. 16T3..</p>	<p>STWC 30°</p>  <p>Page J.17 TC.. 1102.. TC.. 16T3..</p>			

Inserts



Characteristics: Cartridge equipped with square positive inserts and strong cutting edges. The top clamp ensures good rigidity and stability.

For interrupted cut choose cartridge Ref. PSKN (Page: J.09).

Axial: 5.75°
Radial: 1.50°



General turning

CSKP 75°

Ref.		D	h	h ₁	L	L ₁	f	b	Insert size	Kg
CSKP R/L 10CA-09		40	15	10	50	30	14	11	SP..0903..	0,035
CSKP R/L 12CA-12		50	20	12	55	35	20	16	SP..1203..	0,075
CSKP R/L 16CA-12		55	25	16	63	38	25	20	SP..1203..	0,125

Aluminium wheel turning

Automatic lathes

Ref.	CSKP R/L 10CA-09	CSKP R/L 12CA-12	CSKP R/L 16CA-12								
	2304	5025	-	-	1405	1504	5002	2806	1816	5004	
	2305	5003	-	-	1405	1505	5025	2806	1806	5004	
	2305	5003	3112	4002	1406	1505	5025	2808	1808	5005	

Ceramic tools

Ref.	SP..	l	s	d	SPMR-33	SPUN
	SP.. 0903..	9,52	3,18	9,52		
SP.. 1203..	12,70	3,18	12,70			

For more information see page: A.28

Positive 11° clearance - Square inserts

Parting and grooving

Characteristics: Cartridge equipped with square positive inserts and strong cutting edges. The top clamp ensures good rigidity and stability.

For interrupted cut choose cartridge Ref. PSSN (Page: J.10).

Axial: 5°
Radial: 0°



Threading

CSSP 45°

Ref.		D	h	h ₁	L	L ₁	f	b	Insert size	Kg
CSSP R/L 10CA-09		40	15	10	44	24	14	11	SP..0903..	0,035
CSSP R/L 12CA-12		50	20	12	47	27	20	16	SP..1203..	0,065
CSSP R/L 16CA-12		55	25	16	53	28	25	20	SP..1203..	0,090

Cartridges

Ref.	CSSP R/L 10CA-09	CSSP R/L 12CA-12	CSSP R/L 16CA-12							
	2304	5025	-	-	1405	1504	5002	2806	1816	5004
	2305	5003	-	-	1405	1505	5025	2806	1806	5004
	2305	5003	3112	4002	1406	1505	5025	2808	1808	5005

Ref.	SP..	l	s	d	SPMR-33	SPUN
	SP.. 0903..	9,52	3,18	9,52		
SP.. 1203..	12,70	3,18	12,70			

For more information see page: A.28

Positive 11° clearance - Square inserts



Characteristics: Cartridge equipped with triangular positive inserts and strong cutting edges. The top clamp ensures good rigidity and stability.

For interrupted cut choose cartridge Ref. PTFN (Page: J.10).

Axial: 6°
Radial: 0°

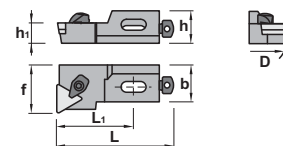
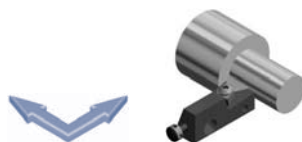

CTFP 90°

Ref.		D	h	h ₁	L	L ₁	f	b	Insert size	kg
CTFP R/L 10CA-11		40	15	10	50	30	14	11	TP..1103..	0,035
CTFP R/L 12CA-16		50	20	12	55	35	20	16	TP..1603..	0,080
CTFP R/L 16CA-16		55	25	16	63	38	25	20	TP..1603..	0,120

Ref.	CTFP R/L 10CA-11	CTFP R/L 12CA-16	CTFP R/L 16CA-16								
	2304	5025	-	-	1405	1504	5002	2806	1816	5004	
	2305	5003	-	-	1405	1505	5025	2806	1806	5004	
	2305	5003	3116	4002	1406	1505	5025	2808	1808	5005	

Ref.	TP..	l	s	d	TPMN	TPMR-33	TPUN	TPUX R/L
					TP.. 1103..	TP.. 1603..	TPMN	TPMR-33
					Positive 11° clearance - Triangular inserts.			

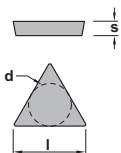

For more information see page: A.31

Positive 11° clearance - Triangular inserts.



Characteristics: Cartridge equipped with triangular positive inserts and strong cutting edges. The top clamp ensures good rigidity and stability.

For interrupted cut choose cartridge Ref. PTGN (Page: J.11).

Axial: 0°
Radial: 4°

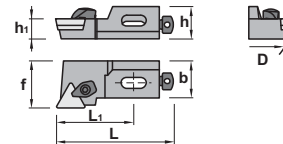
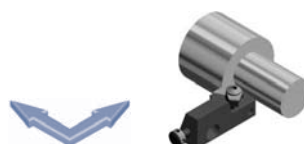

CTGP 90°

Ref.		D	h	h ₁	L	L ₁	f	b	Insert size	kg
CTGP R/L 10CA-11		40	15	10	50	30	14	11	TP..1103..	0,035
CTGP R/L 12CA-16		50	20	12	55	35	20	16	TP..1603..	0,070
CTGP R/L 16CA-16		60	25	16	63	38	25	20	TP..1603..	0,115

Ref.	CTGP R/L 10CA-11	CTGP R/L 12CA-16	CTGP R/L 16CA-16								
	2304	5025	-	-	1405	1504	5002	2806	1816	5004	
	2305	5003	-	-	1405	1505	5025	2806	1806	5004	
	2305	5003	3116	4002	1406	1505	5025	2808	1808	5005	

Ref.	TP..	l	s	d	TPMN	TPMR-33	TPUN	TPUX R/L
					TP.. 1103..	TP.. 1603..	TPMN	TPMR-33
					Positive 11° clearance - Triangular inserts.			

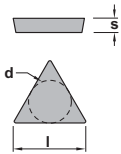

For more information see page: A.31

Positive 11° clearance - Triangular inserts.

Inserts

General turning

Aluminium wheel turning

Automatic lathes

Ceramic tools

Parting and grooving

Threading

Drills

Cartridges



Characteristics: Cartridge equipped with triangular positive inserts and strong cutting edges. The top clamp ensures good rigidity and stability.

For interrupted cut choose cartridge Ref. PTSN (Page: J.11).

Axial: 3.50°
Radial: 3.50°



CTSP 45°

Ref.	D	h	h ₁	L	L ₁	f	b	Insert size	
CTSP R/L 10CA-11	40	15	10	44	24	14	11	TP..1103..	0,035
CTSP R/L 12CA-16	50	20	12	47	27	20	16	TP..1603..	0,075
CTSP R/L 16CA-16	55	25	16	53	28	25	20	TP..1603..	0,140

Ref.	CTSP R/L 10CA-11	CTSP R/L 12CA-16	CTSP R/L 16CA-16							
CTSP R/L 10CA-11	2304	5025	-	-	1405	1504	5002	2806	1816	5004
CTSP R/L 12CA-16	2305	5003	-	-	1405	1505	5025	2806	1806	5004
CTSP R/L 16CA-16	2305	5003	3116	4002	1406	1505	5025	2808	1808	5005

Ref.	TP..	l	s	d	TPMN	TPMR-33	TPUN	TPUX R/L
	TP.. 1103..	11,00	3,18	6,35				
TP.. 1603..	16,50	3,18	9,52					

For more information see page: A.31 Positive 11° clearance - Triangular inserts.

Characteristics: Cartridge equipped with triangular positive inserts and strong cutting edges. The top clamp ensures good rigidity and stability.

For interrupted cut choose cartridge Ref. PTTN (Page: J.12).

Axial: 2.5°
Radial: 4.3°



CTTP 60°

Ref.	D	h	h ₁	L	L ₁	f	b	Insert size	
CTTP R/L 10CA-11	40	15	10	50	30	9	11	TP..1103..	0,040
CTTP R/L 12CA-16	50	20	12	55	35	13	16	TP..1603..	0,075
CTTP R/L 16CA-16	55	25	16	63	38	15	20	TP..1603..	0,115

Ref.	CTTP R/L 10CA-11	CTTP R/L 12CA-16	CTTP R/L 16CA-16							
CTTP R/L 10CA-11	2304	5025	-	-	1405	1504	5002	2806	1816	5004
CTTP R/L 12CA-16	2305	5003	-	-	1405	1505	5025	2806	1806	5004
CTTP R/L 16CA-16	2305	5003	3116	4002	1406	1505	5025	2808	1808	5005

Ref.	TP..	l	s	d	TPMN	TPMR-33	TPUN	TPUX R/L
	TP.. 1103..	11,00	3,18	6,35				
TP.. 1603..	16,50	3,18	9,52					

For more information see page: A.31 Positive 11° clearance - Triangular inserts.



Characteristics: Cartridge equipped with triangular positive inserts and strong cutting edges. The top clamp ensures good rigidity and stability.

For interrupted cut choose cartridge Ref. PTWN (Page: J.12).

Axial: 5.25°
Radial: 3°



CTWP 30°

Ref.		D	h	h1	L	L1	f	b	Insert size	Δ Kg
CTWP R/L 10CA-11		40	15	10	44	24	14	11	TP..1103..	0,035
CTWP R/L 12CA-16		50	20	12	47	27	20	16	TP..1603..	0,065
CTWP R/L 16CA-16		55	25	16	53	28	25	20	TP..1603..	0,105

Ref.											
CTWP R/L 10CA-11		2304	5025	-	-	1405	1504	5002	2806	1816	5004
CTWP R/L 12CA-16		2305	5003	-	-	1405	1505	5025	2806	1806	5004
CTWP R/L 16CA-16		2305	5003	3116	4002	1406	1505	5025	2808	1808	5005

Ref.	TP..	l	s	d	TPMN	TPMR-33	TPUN	TPUX R/L
	TP.. 1103..	11,00	3,18	6,35				
TP.. 1603..	16,50	3,18	9,52					

For more information see page: A.31

Positive 11° clearance - Triangular inserts.

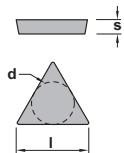

Inserts

General turning

Aluminium wheel turning

Automatic lathes

Ceramic tools

Parting and grooving

Threading

Drills

Cartridges



Characteristics: Cartridge equipped with rhombic negative inserts (angle 80°) and strong cutting edges. The lever lock ensures good rigidity and chip flow in roughing applications.

For low powered machines and small pieces choose cartridge Ref. SCFC (Page: J.13).

Axial: -6°
Radial: -8°

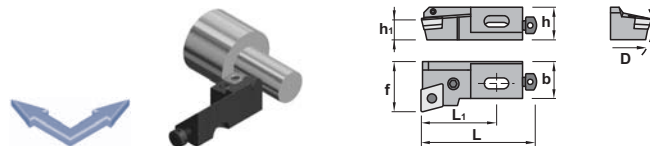

PCFN 90°

Ref.		D	h	h ₁	L	L ₁	f	b	Insert size	Kg
PCFN R/L 16CA-12		60	25	16	63	38	25	20	CNM.. 1204..	0,140
PCFN R/L 20CA-12		70	30	20	70	40	25	20	CNM.. 1204..	0,170
PCFN R/L 25CA-16		100	35	25	100	50	32	25	CNM.. 1606..	0,380

Ref.	PCFN R/L 16CA-12	PCFN R/L 20CA-12	PCFN R/L 25CA-16	8312	1648	5003	3612	4112	1406	1505	0012	5025	2808	1808	5005
				8012	1608	5003	3612	4112	1406	1506	0012	5003	2808	1808	5005
				8016	1618	5003	3616	4115	1408	1508	0015	5004	2810	1810	5006

	CN..	l	s	d	CNMG-CF	CNMG-CM	CNMG-CR	CNMG-CS
	Ref. CN.. 1204..	12,90	4,76	12,70				
	CN.. 1606..	16,10	6,35	15,88				
Negative 80° rhombic inserts					More inserts: CNGP, CNMA, CNMG-CFM, CNMG-CFC, CNMG-CMC, CNMG-CMF, CNMG-CMR, CNMM.			

For more information see page: A.18



Characteristics: Cartridge equipped with rhombic negative double sided insert (angle 80°) with strong cutting edge. The lever lock ensures good rigidity and chip flow in roughing applications.

For low powered machines and small pieces choose cartridge Ref. SCLC (Page: J.13).

Axial: -6°
Radial: -6°

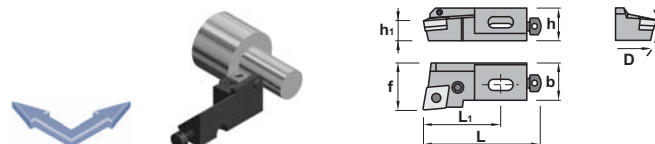

PCLN 95°

Ref.		D	h	h ₁	L	L ₁	f	b	Insert size	Kg
PCLN R/L 16CA-12		60	25	16	63	38	25	20	CNM.. 1204..	0,135
PCLN R/L 20CA-12		70	30	20	70	40	25	20	CNM.. 1204..	0,160
PCLN R/L 25CA-16		100	35	25	100	50	32	25	CNM.. 1606..	0,375

Ref.	PCLN R/L 16CA-12	PCLN R/L 20CA-12	PCLN R/L 25CA-16	8312	1648	5003	3612	4112	1406	1505	0012	5025	2808	1808	5005
				8012	1608	5003	3612	4112	1406	1506	0012	5003	2808	1808	5005
				8016	1618	5003	3616	4115	1408	1508	0015	5004	2810	1810	5006

	CN..	l	s	d	CNMG-CF	CNMG-CM	CNMG-CR	CNMG-CS
	Ref. CN.. 1204..	12,90	4,76	12,70				
	CN.. 1606..	16,10	6,35	15,88				
Negative 80° rhombic inserts					More inserts: CNGP, CNMA, CNMG-CFM, CNMG-CFC, CNMG-CMC, CNMG-CMF, CNMG-CMR, CNMM.			

For more information see page: A.18



Characteristics: Cartridge equipped with square negative inserts and strong cutting edges. The lever lock ensures good rigidity and chip flow in roughing applications.

For low powered machines and small pieces choose cartridge Ref. CSKP (Page: J.04) or SSKC (Page: J.14).

Axial: -4°
Radial: -4°



PSKN 75°		D	h	h ₁	L	L ₁	f	b	Insert size	Kg
Ref.	PSKN R/L 12CA-12	50	20	12	55	35	20	16	SNM.. 1204..	0,080
	PSKN R/L 16CA-12	60	25	16	63	38	25	20	SNM.. 1204..	0,135
	PSKN R/L 20CA-12	70	30	20	70	40	25	20	SNM.. 1204..	0,180
	PSKN R/L 25CA-15	100	35	25	100	50	32	25	SNM.. 1506..	0,400

Ref.	PSKN R/L 12CA-12	PSKN R/L 16CA-12	PSKN R/L 20CA-12	PSKN R/L 25CA-15										
	8212	1626	5025	-	-	1405	1505	-	5025	2806	1806	5004		
	8312	1648	5003	3512	4112	1406	1505	0012	5025	2808	1808	5005		
	8012	1608	5003	3512	4112	1406	1506	0012	5003	2808	1808	5005		
	8016	1618	5003	3515	4115	1408	1508	0015	5004	2810	1810	5006		

	SNM..	l	s	d	SNMA	SNMG-CFM	SNMG-CMR	SNMG-CR	
	Ref.	SNM.. 1204..	12,70	4,76	12,70				
	SNM.. 1506..	15,88	6,35	15,88					
Negative square inserts					For more information see page: A.27				Negative square insert



Characteristics: Cartridge for face turning applications equipped with square negative inserts and strong cutting edges. The lever lock ensures good rigidity and chip flow in roughing applications.

Axial: -11.25°
Radial: -3.25°

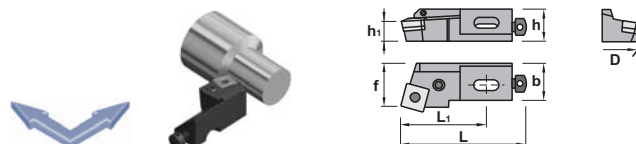

PSRN 75°		D	h	h ₁	L	L ₁	f	b	Insert size	Kg
Ref.	PSRN R/L 16CA-12	60	25	16	63	38	25	20	SNM.. 1204..	0,135
	PSRN R/L 20CA-12	70	30	20	70	40	25	20	SNM.. 1204..	0,180

Ref.	PSRN R/L 16CA-12	PSRN R/L 20CA-12										
	8312	1648	5003	3512	4112	1406	1505	0012	5025	2808	1808	5005
	8012	1608	5003	3512	4112	1406	1506	0012	5003	2808	1808	5005

	SNM..	l	s	d	SNMA	SNMG-CFM	SNMG-CMR	SNMG-CR	
	Ref.	SNM.. 1204..	12,70	4,76	12,70				
Negative square inserts					For more information see page: A.27				Negative square insert

Inserts

General turning

Aluminium wheel turning

Automatic lathes

Ceramic tools

Parting and grooving

Threading

Drills

Cartridges



Characteristics: Cartridge equipped with square negative inserts and strong cutting edges. The lever lock ensures good rigidity and chip flow in roughing applications.

For low powered machines and small pieces choose cartridge Ref. CSSP (Page: J.04) or SSSC (Page: J.14).

Axial: -7°
Radial: -7°

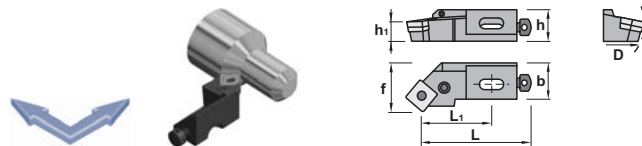

PSSN 45°

Ref.		D	h	h ₁	L	L ₁	f	b	Insert size	Kg
PSSN R/L 12CA-12		50	20	12	47	27	20	16	SNM.. 1204..	0,070
PSSN R/L 16CA-12		60	25	16	53	28	25	20	SNM.. 1204..	0,110
PSSN R/L 20CA-12		70	30	20	60	30	25	20	SNM.. 1204..	0,140

Ref.	PSSN R/L 12CA-12	PSSN R/L 16CA-12	PSSN R/L 20CA-12												
PSSN R/L 12CA-12	8212	1626	5025	-	-	1405	1505	-	5025	2806	1806	5004			
PSSN R/L 16CA-12	8312	1648	5003	3512	4112	1406	1505	0012	5025	2808	1808	5005			
PSSN R/L 20CA-12	8012	1608	5003	3512	4112	1406	1506	0012	5003	2808	1808	5005			

	SNM..	l	s	d	SNMA	SNMG-CFM	SNMG-CMR	SNMG-CR
Ref.	SNM.. 1204..	12,70	4,76	12,70				
Negative square inserts					Negative square insert			

For more information see page: A.27

For more information see page: A.27

Characteristics: Cartridge equipped with triangular negative inserts and strong cutting edges. The lever lock ensures good rigidity and chip flow in roughing applications.

For low powered machines and small pieces choose cartridge Ref. CTFP (Page: J.05) or STFC (Page: J.15).

Axial: -6°
Radial: -8°

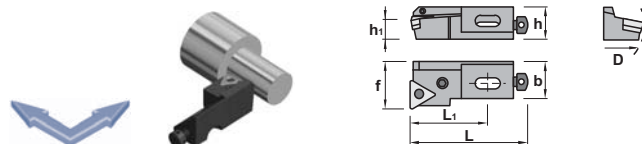

PTFN 90°

Ref.		D	h	h ₁	L	L ₁	f	b	Insert size	Kg
PTFN R/L 12CA-16		50	20	12	55	35	20	16	TNM.. 1604..	0,080
PTFN R/L 16CA-16		60	25	16	63	38	25	20	TNM.. 1604..	0,120
PTFN R/L 20CA-22		70	30	20	70	40	25	20	TNM.. 2204..	0,160
PTFN R/L 25CA-22		100	35	25	100	50	32	25	TNM.. 2204..	0,400

Ref.	PTFN R/L 12CA-16	PTFN R/L 16CA-16	PTFN R/L 20CA-22	PTFN R/L 25CA-22												
PTFN R/L 12CA-16	8216	1605	5002	-	-	1405	1505	-	5025	2806	1806	5004				
PTFN R/L 16CA-16	8009	1606	5025	3416	4109	1406	1505	0009	5025	2808	1808	5005				
PTFN R/L 20CA-22	8012	1608	5003	3422	4112	1406	1506	0012	5003	2808	1808	5005				
PTFN R/L 25CA-22	8012	1608	5003	3422	4112	1408	1508	0012	5004	2810	1810	5006				

	TNM..	l	s	d	TNMG-CF	TNMG-CM	TNMG-CS
Ref.	TNM.. 1604..	16,50	4,76	9,52			
	TNM.. 2204..	22,00	4,76	12,70			
For more information see page: A.29					More inserts: TNMA, TNMG-CFC, TNMG-CFM, TNMG-CMC, TNMG-CMF, TNMG-CMR, TNMX		



Characteristics: Cartridge equipped with triangular negative inserts and strong cutting edges. The lever lock ensures good rigidity and chip flow in roughing applications.

For low powered machines and small pieces choose cartridge Ref. CTGP (Page: J.05) or STGC (Page: J.15).

Axial: -6°
Radial: -10°

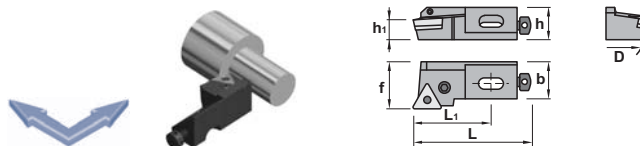

PTGN 90°		D	h	h ₁	L	L ₁	f	b	Insert size	Kg
Ref.	PTGN R/L 12CA-16	50	20	12	55	35	20	16	TNM.. 1604..	0,080
	PTGN R/L 16CA-16	60	25	16	63	38	25	20	TNM.. 1604..	0,120
	PTGN R/L 20CA-22	70	30	20	70	40	25	20	TNM.. 2204..	0,160

Ref.	PTGN R/L 12CA-16	PTGN R/L 16CA-16	PTGN R/L 20CA-22	8216	1605	5002	-	-	1405	1505	-	5025	2806	1806	5004
	PTGN R/L 16CA-16	8009	1606	5025	3416	4109	1406	1505	0009	5025	2808	1808	5005		
	PTGN R/L 20CA-22	8012	1608	5003	3422	4112	1406	1506	0012	5003	2808	1808	5005		

Ref.	TNM..	l	s	d	TNMG-CF	TNMG-CM	TNMG-CS
	TNM.. 1604..	16,50	4,76	9,52			
TNM.. 2204..	22,00	4,76	12,70				

More inserts: TNMA, TNMG-CFC, TNMG-CFM, TNMG-CMC, TNMG-CMF, TNMG-CMR, TNMX

For more information see page: A.29



Characteristics: Cartridge equipped with triangular negative inserts and strong cutting edges. The lever lock ensures good rigidity and chip flow in roughing applications.

For low powered machines and small pieces choose cartridge Ref. CTSP (Page: J.06) or STSC (Page: J.16).

Axial: -7.75°
Radial: -7.75°



PTSN 45°		D	h	h ₁	L	L ₁	f	b	Insert size	Kg
Ref.	PTSN R/L 12CA-16	50	20	12	47	27	20	16	TNM.. 1604..	0,070
	PTSN R/L 16CA-16	60	25	16	53	28	25	20	TNM.. 1604..	0,130
	PTSN R/L 20CA-22	70	30	20	60	30	25	20	TNM.. 2204..	0,165
	PTSN R/L 25CA-22	100	35	25	67	37	32	25	TNM.. 2204..	0,330

Ref.	PTSN R/L 12CA-16	PTSN R/L 16CA-16	PTSN R/L 20CA-22	PTSN R/L 25CA-22	8216	1605	5002	-	-	1405	1505	-	5025	2806	1806	5004
	PTSN R/L 16CA-16	8009	1606	5025	3416	4109	1406	1505	0009	5025	2808	1808	5005			
	PTSN R/L 20CA-22	8012	1608	5003	3422	4112	1406	1506	0012	5003	2808	1808	5005			
	PTSN R/L 25CA-22	8012	1608	5003	3422	4112	1408	1508	0012	5004	2810	1810	5006			

Ref.	TNM..	l	s	d	TNMG-CF	TNMG-CM	TNMG-CS
	TNM.. 1604..	16,50	4,76	9,52			
TNM.. 2204..	22,00	4,76	12,70				

More inserts: TNMA, TNMG-CFC, TNMG-CFM, TNMG-CMC, TNMG-CMF, TNMG-CMR, TNMX

For more information see page: A.29

Cartridges
Brazed tools
Tooling

Inserts

General turning

Aluminium wheel turning

Automatic lathes

Ceramic tools

Parting and grooving

Threading

Drills

Cartridges



Characteristics: Cartridge equipped with triangular negative inserts and strong cutting edges. The lever lock ensures good rigidity and chip flow in roughing applications.

For low powered machines and small pieces choose cartridge Ref. CTTT (Page: J.06) or STTC (Page: J.16).

Axial: -6°
Radial: -10°

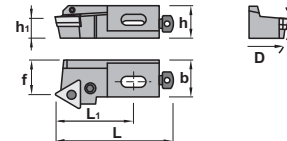
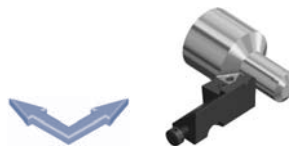

PTTN 60°

Ref.		D	h	h1	L	L1	f	b	Insert size	Kg
PTTN R/L 12CA-16		50	20	12	55	35	13	16	TNM.. 1604..	0,135
PTTN R/L 16CA-16		60	25	16	63	38	15	20	TNM.. 1604..	0,120
PTTN R/L 20CA-22		70	30	20	70	40	15	20	TNM.. 2204..	0,160



Ref.	PTTN R/L 12CA-16	PTTN R/L 16CA-16	PTTN R/L 20CA-22										
	8216	1605	5002	-	-	1405	1505	-	5025	2806	1806	5004	
	8009	1606	5025	3416	4109	1406	1505	0009	5025	2808	1808	5005	
	8012	1608	5003	3422	4112	1406	1506	0012	5003	2808	1808	5005	

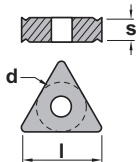

Ref.	TNM..	l	s	d	TNMG-CF	TNMG-CM	TNMG-CS
TNM.. 1604..		16,50	4,76	9,52			
TNM.. 2204..		22,00	4,76	12,70			

More inserts: TNMA, TNMG-CFC, TNMG-CFM, TNMG-CMC, TNMG-CMF, TNMG-CMR, TNMX

For more information see page: A.29

Characteristics: Cartridge equipped with triangular negative inserts and strong cutting edges. The lever lock ensures good rigidity and chip flow in roughing applications.

For low powered machines and small pieces choose cartridge Ref. CTWP (Page: J.07) or STWC (Page: J.17).

Axial: -2.25°
Radial: -8.50°

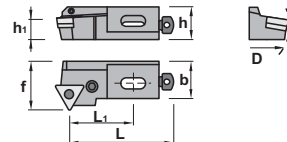

PTWN 30°

Ref.		D	h	h1	L	L1	f	b	Insert size	Kg
PTWN R/L 12CA-16		50	20	12	47	27	20	16	TNM.. 1604..	0,080
PTWN R/L 16CA-16		60	25	16	53	28	25	20	TNM.. 1604..	0,130
PTWN R/L 20CA-22		70	30	20	60	30	25	20	TNM.. 2204..	0,165



Ref.	PTWN R/L 12CA-16	PTWN R/L 16CA-16	PTWN R/L 20CA-22										
	8216	1605	5002	-	-	1405	1505	-	5025	2806	1806	5004	
	8009	1606	5025	3416	4109	1406	1505	0009	5025	2808	1808	5005	
	8012	1608	5003	3422	4112	1406	1506	0012	5003	2808	1808	5005	

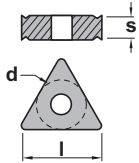

Ref.	TNM..	l	s	d	TNMG-CF	TNMG-CM	TNMG-CS
TNM.. 1604..		16,50	4,76	9,52			
TNM.. 2204..		22,00	4,76	12,70			

More inserts: TNMA, TNMG-CFC, TNMG-CFM, TNMG-CMC, TNMG-CMF, TNMG-CMR, TNMX

For more information see page: A.29



Characteristics: Cartridge equipped with rhombic positive insert (angle 80°).
The center screw ensures good rigidity and chip flow.

Negative inserts cartridge Ref. PCFN (Page: J.08).

Axial: 0°
Radial: 0°

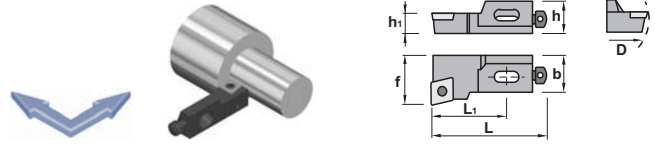

SCFC 90°

Ref.		D	h	h ₁	L	L ₁	f	b	Insert size	Kg
SCFC R/L 06CA-06		20	6	6	25	15	10	6	CCM.. 0602..	0,005
SCFC R/L 08CA-06		25	8	8	27	16	12	7	CCM.. 0602..	0,010
SCFC R/L 10CA-09		30	14	10	42	24	14	10	CCM.. 09T3..	0,030
SCFC R/L 12CA-12		40	16	12	47	35	20	14	CCM.. 1204..	0,060

Ref.									
SCFC R/L 06CA-06	1425	5507	1403	1503	5015	2803	1803	5002	
SCFC R/L 08CA-06	1425	5507	1403	1503	5015	2804	1804	5025	
SCFC R/L 10CA-09	1440	5515	1405	1504	5002	2806	1806	5004	
SCFC R/L 12CA-12	1250	5520	1405	1505	5025	2806	1806	5004	

	CC..	l	s	d	CCGT-AL	CCGT-AP	CCMT-03	CCMW
Ref.	CC.. 0602..	6,45	2,38	6,35				
	CC.. 09T3..	9,65	3,97	9,52				
	CC.. 1204..	12,90	4,76	12,70				

For more information see page: A.18 Positive 7° clearance - 80° Rhombic inserts



Characteristics: Cartridge equipped with rhombic positive insert (angle 80°).
The center screw ensures good rigidity and chip flow.

Negative inserts cartridge Ref. PCLN (Page: J.08).

Axial: 0°
Radial: 0°



SCLC 95°

Ref.		D	h	h ₁	L	L ₁	f	b	Insert size	Kg
SCLC R/L 06CA-06		20	6	6	25	15	10	6	CCM.. 0602..	0,005
SCLC R/L 08CA-06		25	8	8	27	16	12	7	CCM.. 0602..	0,010
SCLC R/L 10CA-09		30	14	10	42	24	14	10	CCM.. 09T3..	0,030
SCLC R/L 12CA-12		40	16	12	47	35	20	14	CCM.. 1204..	0,060

Ref.									
SCLC R/L 06CA-06	1425	5507	1403	1503	5015	2803	1803	5002	
SCLC R/L 08CA-06	1425	5507	1403	1503	5015	2804	1804	5025	
SCLC R/L 10CA-09	1440	5515	1405	1504	5002	2806	1806	5004	
SCLC R/L 12CA-12	1250	5520	1405	1505	5025	2806	1806	5004	

	CC..	l	s	d	CCGT-AL	CCGT-AP	CCMT-03	CCMW
Ref.	CC.. 0602..	6,45	2,38	6,35				
	CC.. 09T3..	9,65	3,97	9,52				
	CC.. 1204..	12,90	4,76	12,70				

For more information see page: A.18 Positive 7° clearance - 80° Rhombic inserts

Inserts



Characteristics: Cartridge equipped with square positive inserts.
The center screw ensures good rigidity and chip flow.

Negative inserts cartridge Ref. PSKN (Page: J.09).

Axial: -1°
Radial: -3.75°

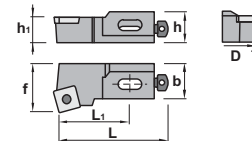

General turning

SSKC 75°

Ref.		D	h	h ₁	L	L ₁	f	b	Insert size	Kg
SSKC R/L 10CA-09		30	14	10	50	30	14	10,0	SC.. 09T3..	0,030
SSKC R/L 12CA-12		40	16	12	55	35	20	14,0	SC.. 1204..	0,065
SSKC R/L 16CA-12		50	20	16	63	38	25	17,5	SC.. 1204..	0,115

Aluminium wheel turning

Automatic lathes

Ref.									
SSKC R/L 10CA-09		1440	5515	1405	1504	5002	2806	1816	5004
SSKC R/L 12CA-12		1250	5520	1405	1505	5025	2806	1806	5004
SSKC R/L 16CA-12		1250	5520	1406	1505	5025	2808	1808	5005

Ceramic tools

	SC..	l	s	d	SCGT-AL	SCMT-03	SCMT-39	SCMW
	Ref. SC.. 09T3..	9,52	3,97	9,52				
	SC.. 1204..	12,70	4,76	12,70				

For more information see page: A.26 Positive 7° clearance - Square inserts.

Parting and grooving

Threading



Characteristics: Cartridge equipped with square positive inserts.
The center screw ensures good rigidity and chip flow.

Negative inserts cartridge Ref. PSSN (Page: J.10).

Axial: -3.5°
Radial: -3.5°

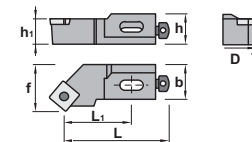

Drills

SSSC 45°

Ref.		D	h	h ₁	L	L ₁	f	b	Insert size	Kg
SSSC R/L 10CA-09		30	14	10	44	24	14	10,0	SC.. 09T3..	0,030
SSSC R/L 12CA-12		40	16	12	47	27	20	14,0	SC.. 1204..	0,055
SSSC R/L 16CA-12		50	20	16	53	28	25	17,5	SC.. 1204..	0,090

Cartridges

Ref.									
SSSC R/L 10CA-09		1240	5515	1405	1504	5002	2806	1816	5004
SSSC R/L 12CA-12		1250	5520	1405	1505	5025	2806	1806	5004
SSSC R/L 16CA-12		1250	5520	1406	1505	5025	2808	1808	5005

	SC..	l	s	d	SCGT-AL	SCMT-03	SCMT-39	SCMW
	Ref. SC.. 09T3..	9,52	3,97	9,52				
	SC.. 1204..	12,70	4,76	12,70				

For more information see page: A.26 Positive 7° clearance - Square inserts.



Characteristics: Cartridge for face turning applications equipped with triangular positive inserts. The center screw ensures good rigidity and chip flow.

Negative inserts cartridge Ref. PTFN (Page: J.10).

Axial: 0°
Radial: -3°



STFC 90°		D	h	h ₁	L	L ₁	f	b	Insert size	Kg
Ref.	STFC R/L 08CA-09	25	8	8	36	15	10	7,0	TC.. 0902..	0,010
	STFC R/L 08CA-11	25	8	8	36	15	11	7,0	TC.. 1102..	0,010
	STFC R/L 10CA-11	30	14	10	50	30	14	10,0	TC.. 1102..	0,035
	STFC R/L 12CA-16	40	16	12	55	35	20	14,0	TC.. 16T3..	0,065
	STFC R/L 16CA-16	50	20	16	63	38	25	17,5	TC.. 16T3..	0,125

Ref.	STFC R/L 08CA-09	1222	5506	1403	1503	5015	2804	1804	5025
	STFC R/L 08CA-11	1225	5507	1403	1503	5015	2804	1804	5025
	STFC R/L 10CA-11	1225	5507	1405	1504	5002	2806	1816	5004
	STFC R/L 12CA-16	1240	5515	1405	1505	5025	2806	1806	5004
	STFC R/L 16CA-16	1240	5515	1406	1505	5025	2808	1808	5005

TC..		l	s	d	TCGT-AL	TCMT-03	TCMW
Ref.	TC.. 0902..	9,62	2,38	5,55			
	TC.. 1102..	11,00	2,38	6,35			
	TC.. 16T3..	16,50	3,97	9,52			

For more information see page: A.28 Positive 7° clearance - Triangular inserts.



Characteristics: Cartridge for face turning applications equipped with triangular positive inserts. The center screw ensures good rigidity and chip flow.

Negative inserts cartridge Ref. PTGN (Page: J.11).

Axial: 0°
Radial: -3°

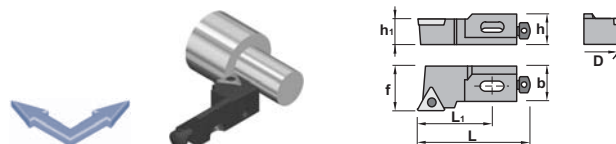

STGC 90°		D	h	h ₁	L	L ₁	f	b	Insert size	Kg
Ref.	STGC R/L 10CA-11	30	14	10	50	30	14	10,0	TC.. 1102..	0,035
	STGC R/L 12CA-16	40	16	12	55	35	20	14,0	TC.. 16T3..	0,065
	STGC R/L 16CA-16	50	20	16	63	38	25	17,5	TC.. 16T3..	0,125

Ref.	STGC R/L 10CA-11	1225	5507	1405	1504	5002	2806	1816	5004
	STGC R/L 12CA-16	1240	5515	1405	1505	5025	2806	1806	5004
	STGC R/L 16CA-16	1240	5515	1406	1505	5025	2808	1808	5005

TC..		l	s	d	TCGT-AL	TCMT-03	TCMW
Ref.	TC.. 1102..	11,00	2,38	6,35			
	TC.. 16T3..	16,50	3,97	9,52			

For more information see page: A.28 Positive 7° clearance - Triangular inserts.

Inserts

General turning

Aluminium wheel turning

Automatic lathes

Ceramic tools

Parting and grooving

Threading

Drills

Cartridges



Characteristics: Cartridge for face turning applications equipped with triangular positive inserts. The center screw ensures good rigidity and chip flow.

Negative inserts cartridge Ref. PTSN (Page: J.11).

Axial: -3.5°
Radial: -3.5°

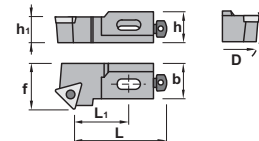

STSC 45°

Ref.		D	h	h1	L	L1	f	b	Insert size	Kg
STSC R/L 08CA-09		25	8	8	27	16	10	7,0	TC.. 0902..	0,005
STSC R/L 08CA-11		25	8	8	27	16	10	7,0	TC.. 1102..	0,005
STSC R/L 10CA-11		30	14	10	44	24	14	10,0	TC.. 1102..	0,035
STSC R/L 12CA-16		40	16	12	47	27	20	14,0	TC.. 16T3..	0,065
STSC R/L 16CA-16		50	20	16	53	28	25	17,5	TC.. 16T3..	0,110

Ref.									
STSC R/L 08CA-09		1222	5506	1403	1503	5015	2804	1804	5025
STSC R/L 08CA-11		1225	5507	1403	1503	5015	2804	1804	5025
STSC R/L 10CA-11		1225	5507	1405	1504	5002	2806	1816	5004
STSC R/L 12CA-16		1240	5515	1405	1505	5025	2806	1806	5004
STSC R/L 16CA-16		1240	5515	1406	1505	5025	2808	1808	5005

Ref.	TC..	l	s	d	TCGT-AL	TCMT-03	TCMW
TC.. 0902..		9,62	2,38	5,55			
TC.. 1102..		11,00	2,38	6,35			
TC.. 16T3..		16,50	3,97	9,52			

For more information see page: A.28 Positive 7° clearance - Triangular inserts.



Characteristics: Cartridge for face turning applications equipped with triangular positive inserts. The center screw ensures good rigidity and chip flow.

Negative inserts cartridge Ref. PTTN (Page: J.12).

Axial: -1.5°
Radial: -2.5°

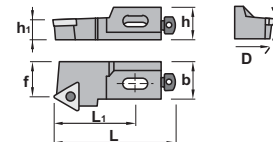

STTC 60°

Ref.		D	h	h1	L	L1	f	b	Insert size	Kg
STTC R/L 08CA-09		25	8	8	27	15	6	7,0	TC.. 0902..	0,010
STTC R/L 08CA-11		25	8	8	27	15	6	7,0	TC.. 1102..	0,010
STTC R/L 10CA-11		30	14	10	50	30	9	10,0	TC.. 1102..	0,035
STTC R/L 12CA-16		40	16	12	55	35	13	14,0	TC.. 16T3..	0,065
STTC R/L 16CA-16		50	20	16	63	38	15	17,5	TC.. 16T3..	0,105

Ref.									
STTC R/L 08CA-09		1222	5506	1403	1503	5015	2804	1804	5025
STTC R/L 08CA-11		1225	5507	1403	1503	5015	2804	1804	5025
STTC R/L 10CA-11		1225	5507	1405	1504	5002	2806	1816	5004
STTC R/L 12CA-16		1240	5515	1405	1505	5025	2806	1806	5004
STTC R/L 16CA-16		1240	5515	1406	1505	5025	2808	1808	5005

Ref.	TC..	l	s	d	TCGT-AL	TCMT-03	TCMW
TC.. 0902..		9,62	2,38	5,55			
TC.. 1102..		11,00	2,38	6,35			
TC.. 16T3..		16,50	3,97	9,52			

For more information see page: A.28 Positive 7° clearance - Triangular inserts.



Characteristics: Cartridge for face turning applications equipped with triangular positive inserts. The center screw ensures good rigidity and chip flow.

Negative inserts cartridge Ref. PTWN (Page: J.12).

Axial: -1.5°
Radial: -2.5°

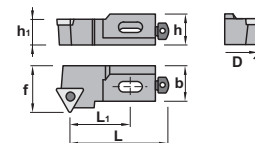

STWC 30°										
Ref.		D	h	h ₁	L	L ₁	f	b	Insert size	Δ Kg
	STWC R/L 08CA-11	25	8	8	27	16	10	7,0	TC.. 1102..	0,005
	STWC R/L 10CA-11	30	14	10	44	24	14	10,0	TC.. 1102..	0,035
	STWC R/L 12CA-16	40	16	12	47	27	20	14,0	TC.. 16T3..	0,065
	STWC R/L 16CA-16	50	20	16	53	28	25	17,5	TC.. 16T3..	0,110

Ref.									
	STWC R/L 08CA-11	1225	5507	1403	1503	5015	2804	1804	5025
	STWC R/L 10CA-11	1225	5507	1405	1504	5002	2806	1816	5004
	STWC R/L 12CA-16	1240	5515	1405	1505	5025	2806	1806	5004
	STWC R/L 16CA-16	1240	5515	1406	1505	5025	2808	1808	5005

	TC..				TCGT-AL	TCMT-03	TCMW
	Ref.	l	s	d			
	TC.. 1102..	11,00	2,38	6,35			
TC.. 16T3..	16,50	3,97	9,52				

For more information see page: A.28

Positive 7° clearance - Triangular inserts.