

**MANUFACTURED FROM FORGED PARTS****MATERIAL:**

- Alloyed carburized steel at chrome-manganese 1.7131 (16MnCr5).

**EXECUTION:**

- Carburized, hardness.
- Surface hardness HRC 58±2 (670±40 HV30)
- Depth minimum 0,5 mm.
- Tensile strength in core minimum 800 N/mm<sup>2</sup> after carburizing.

**ACCURACY:**

- Taper according to DIN 254
- Taper angle:  
tolerance AT 3 DIN 7178 part 1 and DIN 2080 part 1.
- Other tolerances according to DIN 7160 and 7168.
- Taper surface roughness  $R_z < 0,001$  mm.

**HERGESTELLT AUS GESCHMIEDETEN TEILEN****MATERIAL:**

- Legierter Aufgekohlter Stahl mit Chrom-Mangan 1.7131 (16MnCr5).

**KONSTRUKTIONSDATEN:**

- Aufgekühlt, gehärtet und angelassen.
- Oberflächenhärte HRC 58±2 (670±40 HV30).
- Aufgekühlt auf minimum 0,5 mm Tiefe.
- Zugfestigkeit im Kern minimum 800 N/mm<sup>2</sup> nach der Aufkohlung.

**GENAUIGKEIT:**

- Dorn nach DIN 254.
- Kegelwinkel:  
Toleranz AT 3 DIN 7178 Teil 1 und DIN 2080 Teil 1.
- Andere Toleranzen entsprechend DIN 7160 und 7168.
- Rauigkeit der Oberfläche  $R_z < 0,001$  mm.

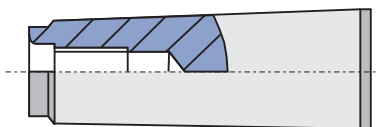
**TOLERANCE AT :**

- Indicates the tolerance of size D surface between the real and the theoretical value of the taper conicity.
- This value of surface D must always be less (negative), never more (positive) in order to GUARANTEE a good toolholder fixation at the bigger taper diameter.

**TOLERANZ AT :**

- Zeigt die Toleranz auf der Messebene D zwischen dem tatsächlichen Wert der Kegelkonizität und dem theoretischen Wert.
- Dieser Wert auf der Messebene D sollte immer minus (negativ) sein, nie plus (positiv), um für einen guten Halt des Futterers in den größeren Durchmesser des Kegels zu garantieren.

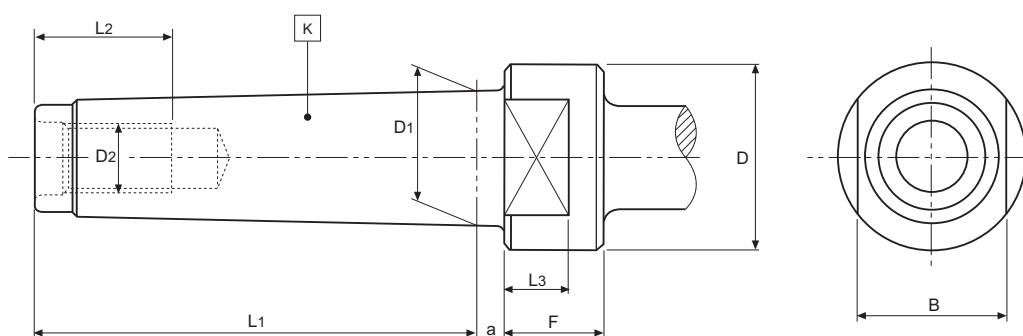
**DIN 228A/B**

MORSE	L <sub>1</sub> mm	L <sub>2</sub> mm	L <sub>3</sub> mm	D mm	D <sub>1</sub> mm	D <sub>2</sub> mm	F min mm	B d9 mm	a mm
1	53,5	16	-	-	12,065	M-6	-	-	3,5
2	64,0	24	-	-	17,780	M-10	-	-	5,0
3	81,0	24	12	36	23,825	M-12	18	24	5,0
4	102,5	32	15	43	31,267	M-16	23	32	6,5
5	129,5	40	18	60	44,399	M-20	28	45	6,5
6	182,0	47	25	84	63,348	M-24	39	65	8,0

<p><b>30.315</b></p>  <p>I.02</p>	<p><b>36.453</b></p>  <p>I.03</p>	<p><b>37.215</b></p>  <p>I.04</p>	<p><b>37.290</b></p>  <p>I.05</p>	<p><b>37.295</b></p>  <p>I.06</p>
<p><b>37.296</b></p>  <p>I.07</p>				

10  
DIN 2080

11 13  
DIN 69871-A

16  
HSK DIN 69893-1

17  
TS ISO 26622-1

18  
PSC ISO 26623-1

20 23  
JIS B 6339-BT

25  
CHIRON

BORING HEADS  
BOHRKÖPFE

MORSE SHANKS  
MORSE SCHÄPFTE

# 30.315

**MORSE MODULAR SHANKS**  
for modular milling heads  
**MORSE MODULAR-SCHÄPFTE**  
Für Modular-Fräsköpfe

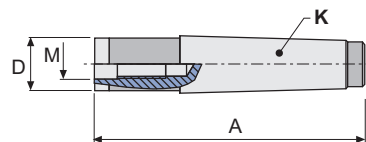



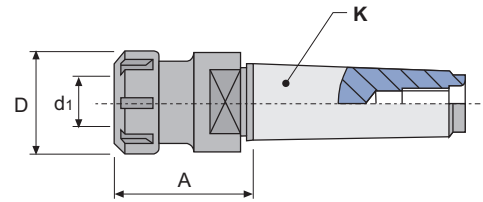

REF.	K MORSE	A mm	M mm	D mm	kg
30.315.03.08	3	125	M8	14	0,290
30.315.03.10	3	125	M10	18	0,300
30.315.03.12	3	125	M12	21	0,305
30.315.04.16	4	154	M16	29	0,670

DIN 228/A  
**36.453**

TREADED MORSE TAPER CHUCK FOR ER COLLETS DIN 6499/B  
SPANNZANGENAUFNAHME MIT MORSEKEGEL UND ANZUGSGEWINDE FÜR  
SPANNZANGEN DIN 6499/B



REF.	K MORSE		A mm	D mm	d <sub>1</sub> mm				
36.453.03.32	3	ER32	70	50	2-20	45332	50232	19218	0,600
36.453.03.40		ER40	80	63	4-30	45340	50240	19224	0,950
36.453.04.32	4	ER32	60	50	2-20	45332	50232	19218	0,700
36.453.04.40		ER40	81	63	4-30	45340	50240	19224	1,200

\* SUPPLIED WITHOUT WRENCH / \* GELIEFERT OHNE SCHLÜSSEL

REF.	ACCESSORIES / ZUBEHÖR
ERXX	Collets double slot DIN 6499 - Form B (ER) / Spannzangen mit Doppelnut DIN 6499 - Form B (ER)
ERCXX	Sealed collets DIN 6499 (ER) / Abgedichtete Spannzangen DIN 6499 (ER)

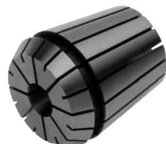

ERXX



ERCXX

For more information see page / Für weitere Informationen siehe Seite: K.13, K.17

10  
DIN 208011 13  
DIN 69871-A16  
HSK DIN 69893-117  
TS ISO 26622-118  
PSC ISO 26623-120 23  
JIS B 6339-BT25  
CHIRONBORING HEADS  
BOHRKÖPFEMORSE SHANKS  
MORSE SCHÄPFTE

DIN 228/B

37.215

PRECISION DRILL CHUCK ARBORS

KEGEL-AUFSTECKDORNE FÜR BOHRFUTTERAUFNAHMEN

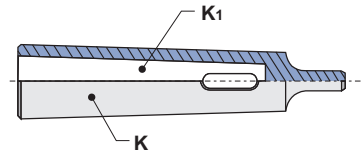

REF.	K MORSE	K <sub>1</sub> MORSE	kg
37.215.02.01	2	1	0,230
37.215.03.01	3	1	-
37.215.03.02	3	2	-
37.215.04.02	4	2	0,450
37.215.04.03	4	3	-
37.215.05.03	5	3	1,170
37.215.05.04	5	4	1,030

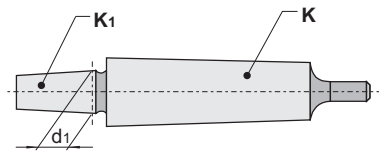

REF.	K MORSE	K <sub>1</sub> DIN	d <sub>1</sub> mm	
37.290.02.12	2	B-12	12,065	0,100
37.290.02.16		B-16	15,733	-
37.290.02.18		B-18	17,780	0,200
37.290.03.12	3	B-12	12,065	0,150
37.290.03.16		B-16	15,733	0,320
37.290.03.18		B-18	17,780	0,400
37.290.04.16	4	B-16	15,733	0,630
37.290.04.18		B-18	17,780	0,660

REF.	ACCESSORIES / ZUBEHÖR
MU	Standard keyless drill chucks DIN 238 / Standard Schnellspann-Bohrfutter DIN 238
MP	Precision keyless drill chucks DIN 238 / Schnellspann-Bohrfutter DIN 238, Genauigkeitsausführung
MK	Self clamping precision keyless drill chucks DIN 238 / Selbstspann-Bohrfutter DIN 238, Genauigkeitsausführung
MH	CNC-UNIVERSAL precision drill chucks DIN 238 / CNC-Universaler Bohrfutter DIN 238, Genauigkeitsausführung



MU



MP



MK



MH

For more information see page / Für weitere Informationen siehe Seite: K.02, K.03, K.04, K.05

DIN 228/B

**37.295****SELF CLAMPING SHORT PRECISION DRILL CHUCKS**

for right turn only

**KURZE SELBSTPANN-BOHRFUTTER, GENAUIGKEIT-AUSFÜHRUNG**

nur für Rechtsumdrehung

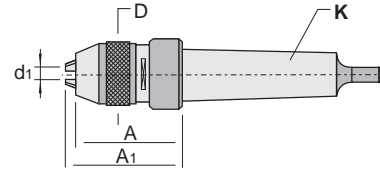

REF.	K MORSE	d <sub>1</sub> mm	D mm	A mm	A <sub>1</sub> max mm	 Kg
37.295.02.08	2	0 - 8	35	56	65	-
37.295.02.13		0-13	51	81	95	1,060
37.295.03.13	3	0-13	51	81	95	-
37.295.03.16		3-16	56	85	98	-
37.295.04.13	4	0-13	51	81	95	1,880
37.295.04.16		3-16	56	85	98	-

\* SUPPLIED WITH WRENCH / \* GELIEFERT MIT SCHLÜSSEL

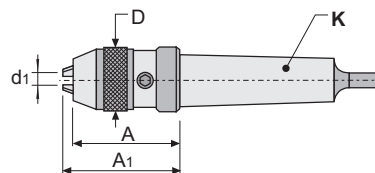

REF.	
37.295.02.08	50008
37.295.02.13	50013
37.295.03.13	50013
37.295.03.16	50016
37.295.04.13	50013
37.295.04.16	50016



REF.	K MORSE	d <sub>1</sub> mm	D mm	A mm	A <sub>1</sub> max mm	⚖ kg
37.296.02.13	2	1-13	50	85	92	1,120
37.296.03.13	3	1-13	50	85	92	1,270
37.296.03.16		3-16	56	92	99	1,570
37.296.04.13	4	1-13	50	85	92	1,590
37.296.04.16		3-16	56	92	99	1,850
37.296.05.16	5	3-16	56	92	99	2,750

Morse shank being part of the drill chuck, solving coupling problems of any other systems.  
Da der Morse-Schaft ein Teil des Bohrfutters ist, das löst die Kupplungsprobleme von den anderen Systemen.

\* SUPPLIED WITH WRENCH / \* GELIEFERT MIT SCHLÜSSEL

REF.		3 x 
37.296.02.13	50706	60313
37.296.03.13	50706	60313
37.296.03.16	50706	60313
37.296.04.13	50706	60313
37.296.04.16	50706	60313
37.296.05.16	50706	60313